

GB Cable-Pulling Systems

D Kabeleinzugsysteme

F Tire-fils

€ Guías Pasacable

I Sonde Passacavi

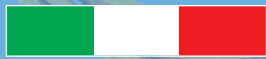

MADE IN ITALY

ARLINE

Manufacturers since 1944

Hersteller seit 1944

Fabrication depuis 1944

Fabricación desde 1944

Fabbrichiamo dal 1944

AR-line

GB Draw-in tape with interchangeable accessories threaded directly on Perlon.

D Einziehband mit austauschbaren Endstücken. Gewinde direkt auf Perlonstab.

F Tirefil avec des terminaux interchangeables filetés sur Perlon.

E Guía pasacable con punta intercambiable roscado directamente en el Perlon.

I Passacavo con accessori intercambiabili, filettati direttamente sul filo Perlon.

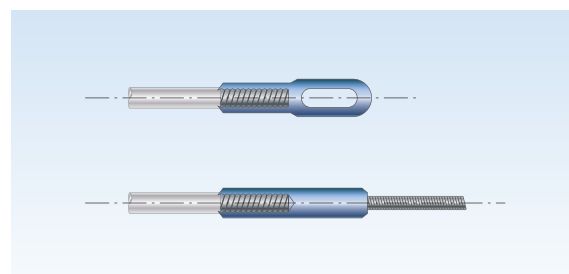

Item	Length	
A405	5 m	20
A410	10 m	20
A415	15 m	20
A420	20 m	10
A425	25 m	10
A430	30 m	10

GB Spare parts

D Ersatzteile

F Pièces de rechange

E Piezas de repuestos

I Ricambi

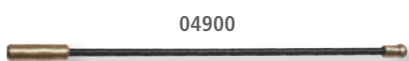

04900

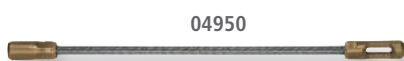

04950



046/GR



043

GB Draw-in tape with interchangeable accessories threaded on brass.

D Einziehband mit austauschbaren Endstücken. Gewinde auf Messing.

F Tirefil avec des terminaux interchangeables filetés sur laiton.

E Guía pasacable con punta intercambiable roscado en el latón.

I Passacavo con accessori intercambiabili, filettati su ottone.

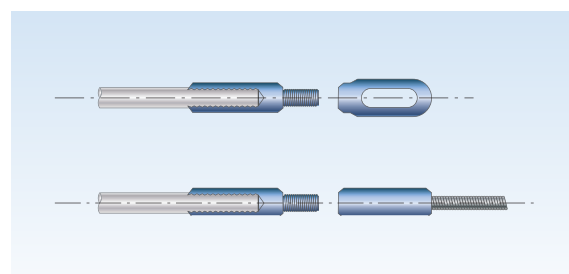

Item	Length	
B405	5 m	20
B410	10 m	20
B415	15 m	20
B420	20 m	10
B425	25 m	10
B430	30 m	10

Nylon \varnothing 4 mm



- GB** Draw-in tape with interchangeable accessories threaded directly on nylon.
- D** Einziehband mit austauschbaren Endstücken. Gewinde direkt auf Nylonstab.
- F** Tirefil avec des terminaux interchangeables filetés sur nylon.
- E** Guía pasacable con punta intercambiable roscado directamente en el nylon.
- I** Passacavo con accessori **intercambiabili**, filettati direttamente sul nylon.

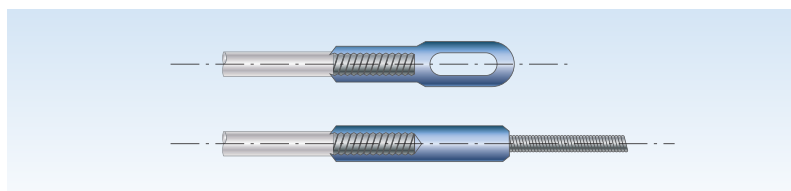

Item N400	Item 5100	Length	
N405	5100.05	5 m	100/20
N410	5100.10	10 m	60/20
N415	5100.15	15 m	50/20
N420	5100.20	20 m	40/10
N425	5100.25	25 m	30/10
N430	5100.30	30 m	25/10

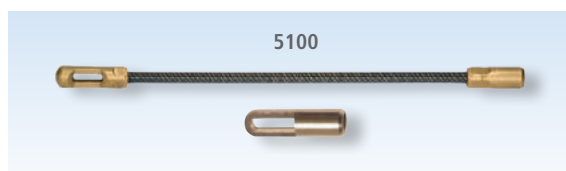
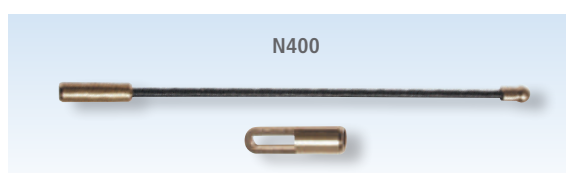

Nylon \varnothing 3 mm



- GB** Draw-in tape with fixed heads.
- D** Einziehband mit direkt gepressten Endstücken.
- F** Tirefil avec des terminaux fixes.
- E** Guía pasacable con punta fija.
- I** Passacavo con terminali **fissi**

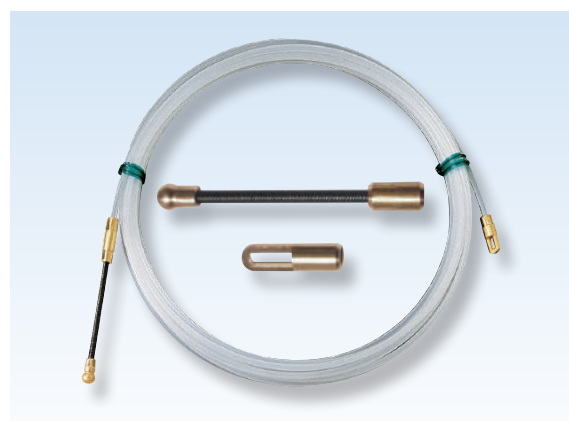

Item	Length	
N305	5 m	150/20
N310	10 m	100/20
N315	15 m	80/20
N320	20 m	50/10
N325	25 m	40/10
N330	30 m	35/10

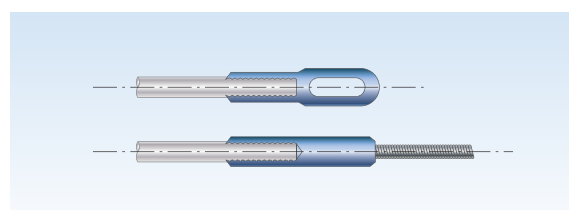

Twisted polyester \varnothing 3 mm



- GB** Polyester helicoidal monofilament rod with **fixed heads**. Friction reduced thanks to the halved contact surface.
- D** Schraubeförmige Kabeleinziehsonde aus Polyester Monofilament, reduziert Reibung. **Mit direct gepressten Endstücken.**
- F** Tirefil de polyester guipée monofilament, réduit la friction. Avec **terminaux fixes.**
- E** Guía pasacable monofilamento de poliéster helicoidal con **punta fija**. Por sus crestas helicoidales tiene menor resistencia a penetrar en el tubo.
- I** Sonda elicoidale in poliesterone monofilo con doppio **puntale fisso**. Riduce al minimo l'attrito perché la superficie di contatto è dimezzata

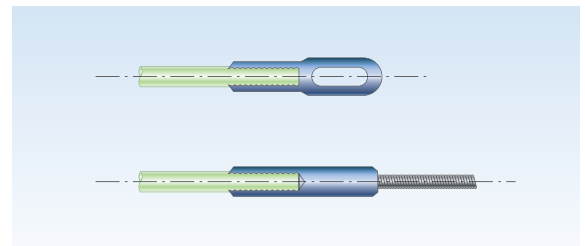
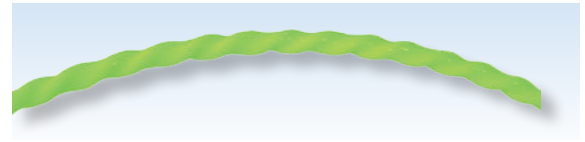

Item	Length	
PM0310F	10 m	5
PM0315F	15 m	5
PM0320F	20 m	5

- GB** Polyester helicoidal monofilament rod with **interchangeable accessories M 3,5**. Friction reduced thanks to the halved contact surface.
- D** Schraubeförmige Kabeleinziehsonde aus Polyester Monofilament, reduziert Reibung. **Mit austauschbaren Endstücken M 3,5.**
- F** Tirefil de polyester guipée monofilament, réduit la friction. Avec **terminaux interchangeable M 3,5.**
- E** Guía pasacable monofilamento de poliéster helicoidal con **punta intercambiable M 3,5**. Por sus crestas helicoidales tiene menor resistencia a penetrar en el tubo.
- I** Sonda elicoidale in poliesterone monofilo con **accessori intercambiabili M 3,5**. Riduce al minimo l'attrito perché la superficie di contatto è dimezzata.

Item	Length	
PM0310	10	5
PM0315	15	5
PM0320	20	5

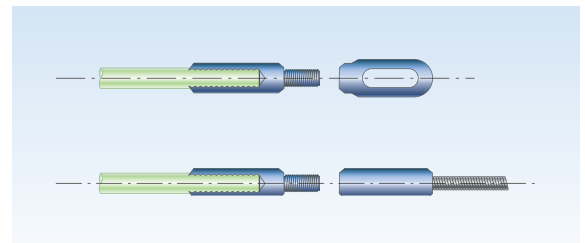

GB Accessories and spare parts

D Zubehör und Ersatzteile

F Accessoires et pièces de rechange

E Accesorios y piezas de repuestos

I Accessori e pezzi di ricambio



03020



03015

Twisted polyester \varnothing 4,5-5,2 mm



- GB** Polyester helicoidal rod (3 wire) with **interchangeable accessories** M5. Friction reduced thanks to the halved contact surface.
- D** Schraubeförmige Kabeleinziehsonde aus Polyester (3 Draht), reduziert Reibung. **Mit austauschbaren Endstücken** M5.
- F** Tirefil de polyester guipée (3 fils), réduit la friction. Avec terminaux **interchangeable** M5.
- E** Guía pasacable de poliéster helicoidal (3 hilos) **con punta intercambiable** M5. Por sus crestas helicoidales tiene menor resistencia a penetrar en el tubo.
- I** Sonda elicoidale in poliester (3 fili) **con accessori intercambiabili** M5. Riduce al minimo l'attrito perché la superficie di contatto è dimezzata.

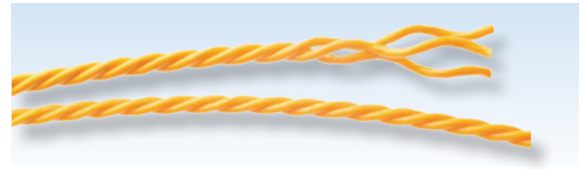

Item	Length	\varnothing	
PT4510	10 m	4,5 mm	5
PT4515	15 m	4,5 mm	5
PT4520	20 m	4,5 mm	5
PT4525	25 m	4,5 mm	5
PT4530	30 m	4,5 mm	5
PT5225	25 m	5,2 mm	3
PT5230	30 m	5,2 mm	3
PT5240	40 m	5,2 mm	3
PT5250	50 m	5,2 mm	3

- GB** Polyester helicoidal monofilament rod with **interchangeable accessories** M5. Friction reduced thanks to the halved contact surface.
- D** Schraubeförmige Kabeleinziehsonde aus Polyester Monofilament, reduziert Reibung. **Mit austauschbaren Endstücken** M5.
- F** Tirefil de polyester guipée monofilament, réduit la friction. Avec terminaux **interchangeable** M5.
- E** Guía pasacable monofilamento de poliéster helicoidal **con punta intercambiable** M5. Por sus crestas helicoidales tiene menor resistencia a penetrar en el tubo.
- I** Sonda elicoidale in poliester monofilo **con accessori intercambiabili** M5. Riduce al minimo l'attrito perché la superficie di contatto è dimezzata.

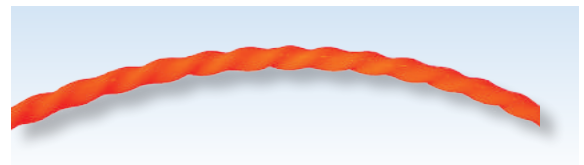

Item	Length	\varnothing	
PM4510	10 m	4,5 mm	5
PM4515	15 m	4,5 mm	5
PM4520	20 m	4,5 mm	5
PM4525	25 m	4,5 mm	5
PM4530	30 m	4,5 mm	3

GB Standard accessories and spare parts

D Standard zubehör und Ersatzteile

F Accessoires standard et pièces de rechange

E Accesorios standard y piezas de repuestos

I Accessori standard e pezzi di ricambio

450020

GB Flexible starting spinner \varnothing 7 M5.

D Flexible Federführungs Kopf mit Zugöse \varnothing 7 M5.

F Tête flexible avec oeillet \varnothing 7 M5.

E Punta flexible con ojal de tiro \varnothing 7 M5.

I Puntale flessibile con asola \varnothing 7 M5.



072/5

GB Pulling eyelet \varnothing 7 M5.

D Kopf mit Zugöse \varnothing 7 M5.

F Embout avec oeillet \varnothing 7 M5.

E Punta ojal \varnothing 7 M5.

I Tirante con asola \varnothing 7 M5.



GB Special accessories and spare parts

D Sonder-Zubehör und Ersatzteile

F Accessoires spéciaux et pièces de rechange

E Accesorios especiales y piezas de repuestos

I Accessori speciali e pezzi di ricambio

450010

GB Flexible starting spinner \varnothing 9 M5.

D Flexible Federführungs Kopf mit Zugöse \varnothing 9 M5.

F Tête flexible avec oeillet \varnothing 9 M5.

E Punta flexible con ojal de tiro \varnothing 9 M5.

I Puntale flessibile con asola \varnothing 9 M5.



130605 3/A

GB Pulling eyelet \varnothing 9 M5.

D Kopf mit Zugöse \varnothing 9 M5.

F Embout avec oeillet \varnothing 9 M5.

E Punta ojal \varnothing 9 M5.

I Tirante con asola \varnothing 9 M5.



Aspo 300

GB Vertical steel reel.

D Senkrechte Stahl-haspel.

F Enrouleur en acier vertical.

E Contenedor vertical de acero.

I Aspo avvolgitore in acciaio verticale.

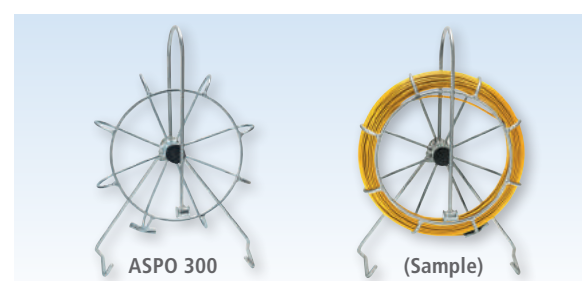

Polypropylene-steel flat \varnothing 4 mm



- GB** Rod made of flat steel covered with PP with interchangeable accessories M5.
- D** Flachstahl Einziehband mit PP Ummantelung, mit austauschbaren Endstücken M5.
- F** Tirefil avec âme plate en acier, revêtement en PP avec des terminaux interchangeable M5.
- E** Guía pasacable en fleje acero recubierto de PP con punta intercambiable M5.
- I** Sonda passacavo in acciaio piatto rivestito in PP con accessori intercambiabili M5.



WARNING! This is a tool only for professional use. Risk of electrical shock. For your safety **DO NOT USE** in ducts with voltage cables.
ATTENZIONE! Rischio di shock elettrico **NON USARE** in tubi con presenza di cavi in tensione elettrica.

Item	Length	
0419.10	10 m	5
0419.15	15 m	5
0419.20	20 m	5
0419.25	25 m	5

GB Accessories and spare parts

D Zubehör und Ersatzteile

F Accessoires et pièces de rechange

E Accesorios y piezas de repuestos

I Accessori e pezzi di ricambio



101050



101024

Polypropylene-steel wire \varnothing 4 mm



- GB** Steel wire draw-in tape covered with PP, with interchangeable accessories M5.
- D** Stahldraht mit PP Ummantelung, mit austauschbaren Endstücken M5.
- F** Tirefil avec âme flexible en fil d'acier revêtement en PP. Avec des terminaux interchangeables M5.
- E** Guía pasacable con núcleo de hilo de acero recubierto de PP con punta intercambiable M5.
- I** Passacavo in filo d'acciaio ricoperto in PP. Accessori intercambiabili M5.

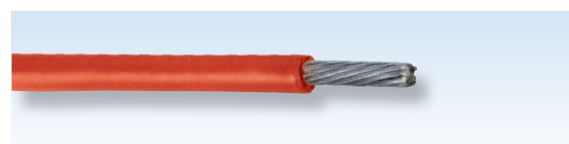

WARNING! This is a tool only for professional use. Risk of electrical shock. For your safety **DO NOT USE** in ducts with voltage cables.
ATTENZIONE! Rischio di shock elettrico **NON USARE** in tubi con presenza di cavi in tensione elettrica.

Item	Length	
4619.05	5 m	5
4619.10	10 m	5
4619.15	15 m	5
4619.20	20 m	5
4619.25	25 m	5
4619.30	30 m	5

GB Accessories and spare parts

D Zubehör und Ersatzteile

F Accessoires et pièces de rechange

E Accesorios y piezas de repuestos

I Accessori e pezzi di ricambio



101050



101024

Polypropylene-steel flat \varnothing 6 mm



- GB** Rod made of flat steel covered with PP with interchangeable accessories M5.
- D** Flachstahl Einziehband mit PP Ummantelung, mit austauschbaren Endstücken M5.
- F** Tirefil avec âme plate en acier, revêtement en PP avec des terminaux interchangeable M5.
- E** Guía pasacable en fleje acero recubierto de PP con punta intercambiable M5.
- I** Sonda passacavo in acciaio piatto rivestito in PP con accessori intercambiabili M5.

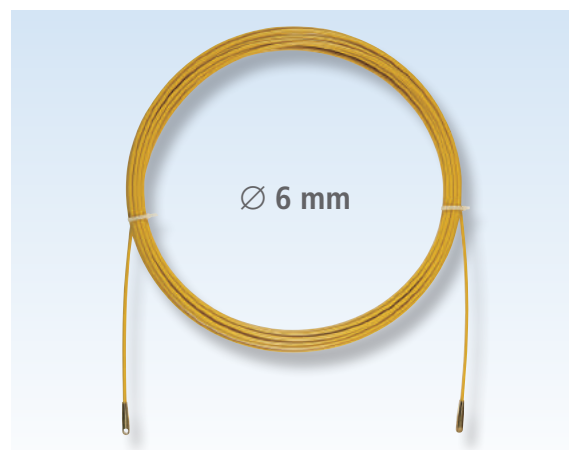

WARNING! This is a tool only for professional use. Risk of electrical shock. For your safety **DO NOT USE** in ducts with voltage cables.
ATTENZIONE! Rischio di shock elettrico **NON USARE** in tubi con presenza di cavi in tensione elettrica.

Item	Length	
AR620	20 m	5/1
AR630	30 m	5/1
AR640	40 m	5/1
AR650	50 m	5/1
AR660	60 m	5/1

GB Accessories and spare parts

D Zubehör und Ersatzteile

F Accessoires et pièces de rechange

E Accesorios y piezas de repuestos

I Accessori e pezzi di ricambio

064/B

- GB** Standard Starting spinner \varnothing 11 M5.
- D** Standard Federführungs Kopf mit Zugöse \varnothing 11 M5.
- F** Tête standard avec oeillet \varnothing 11 M5.
- E** Punta standard con ojal de tiro \varnothing 11 M5.
- I** Puntale standard con asola \varnothing 11 M5.

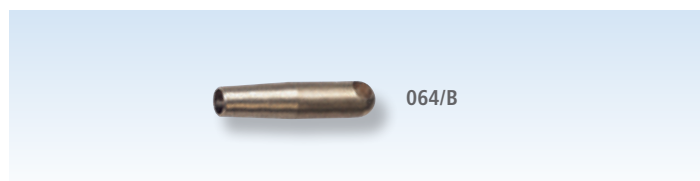

AR697

- GB** Starting roller for AR691.
- D** Führungsrolle für AR691.
- F** Roue pour AR691.
- E** Ruedas para AR691.
- I** Ruota di scorrimento per AR691.

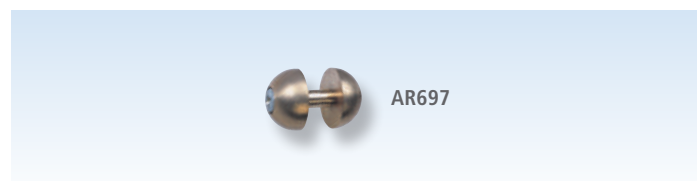

AR695

- GB** Flexible starting spinner \varnothing 10 M5.
- D** Flexible Federführungs Kopf \varnothing 10 M5.
- F** Tête flexible \varnothing 10 M5.
- E** Punta flexible \varnothing 10 M5.
- I** Puntale flessibile \varnothing 10 M5.



Aspo 600

- GB** Horizontal steel reel.
- D** Liegende Stahl-haspel.
- F** Horizontal Enrouleur en acier.
- E** Contenedor horizontal de acero.
- I** Aspo avvolgitore orizzontale in acciaio.



- GB** Rod made of flat steel covered with PP with interchangeable accessories M5.
- D** Flachstahl Einziehband mit PP Ummantelung, mit austauschbaren Endstücken M5.
- F** Tirefil avec âme plate en acier, revêtement en PP avec des terminaux interchangeable M5.
- E** Guía pasacable en fleje acero recubierto de PP con punta intercambiable M5.
- I** Sonda passacavo in acciaio piatto rivestito in PP con accessori intercambiabili M5.



WARNING! This is a tool only for professional use. Risk of electrical shock. For your safety **DO NOT USE** in ducts with voltage cables.
ATTENZIONE! Rischio di shock elettrico **NON USARE** in tubi con presenza di cavi in tensione elettrica.

Item	Length	
AR1040	40 m	1
AR1050	50 m	1
AR1060	60 m	1

- GB** Special accessories and spare parts
- D** Sonder-Zubehör und Ersatzteile
- F** Accessoires spéciaux standard et pièces de rechange
- E** Accesorios especiales standard y piezas de repuestos
- I** Accessori speciali standard e pezzi di ricambio

103/B

- GB** Standard Starting spinner \varnothing 20 M5.
- D** Standard Federführungs Kopf mit Zugöse \varnothing 20 M5.
- F** Tête standard avec oeillet \varnothing 20 M5.
- E** Punta standard con ojal de tiro \varnothing 20 M5.
- I** Puntale standard con asola \varnothing 20 M5.

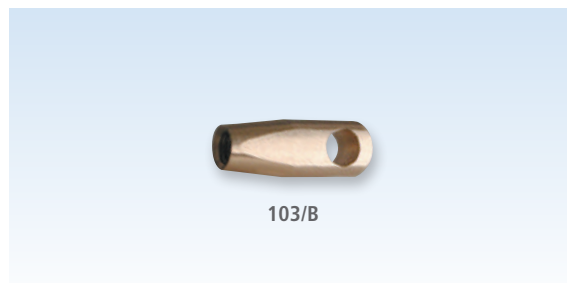

103304

- GB** Special starting roller \varnothing 25 M5.
- D** Anfangsrolle \varnothing 25 M5.
- F** Ogive M5 avec rove \varnothing 25.
- E** Cabeza guía M5 rueda \varnothing 25.
- I** Puntale M5 con ruota \varnothing 25.



Aspo 800

- GB** Vertical steel reel.
- D** Senkerechte Stahl-haspel.
- F** Enrouleur en acier vertical.
- E** Contenedor vertical de acero.
- I** Aspo avvolgitore in acciaio verticale.



Arrow Rod is the right professional Tool for Electricians in installations in floating floors, in false ceiling, in empty walls and where are not available cable ducts. The revolutionary raw material "Fiber Basalt" give to our new item the best flexibility and at the same time the best resistance. **Arrow Rod Set** will be essential in electrical installation. To facilitate using of the components, it comes in a flexible strong bag

item **4719.05** set composed by:

- 2 pcs. rod Ø 5,6mm L=1m,
- 3 pcs. rod Ø 4,6mm L=1m,
- 1 pc. flexible extension cord
- 1 pc. round starting head
- 1 pc. pulling eyelet with ring
- 1 pc. magnet
- 1 pc. chain

Item **4719.10** set composed by:

- 3 pcs. rod Ø 6,6mm L=1m,
- 3 pcs. rod Ø 5,6mm L=1m,
- 3 pcs. rod Ø 4,6mm L=1m,
- 1 pc. rod Ø 4,0mm L=1m,
- 1 pc. flexible extension cord
- 1 pc. round starting head
- 1 pc. pulling eyelet with ring

- 1 pc. magnet
- 1 pc. chain
- 1 pc. super

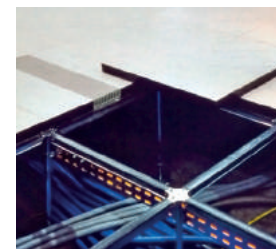

GB Special accessories and spare parts

D Sonder-Zubehör und Ersatzteile

F Accessoires spéciaux standard et pièces de rechange

E Accesorios especiales standard y piezas de repuestos

I Accessori speciali standard e pezzi di ricambio

4719.Led

GB Starting head with LED.

- D** Starke LED Leuchte.
- F** Ampoule LED.
- E** Bombilla LED.
- I** Puntale con luce LED.

4719.Led

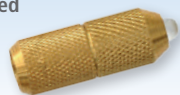

4719.H

GB Hook.

- D** Haken.
- F** Crochet.
- E** Gancho.
- I** Gancio.

4719.H



4719.T

GB Threader.

- D** Gewindeschneider.
- F** Fileteuse.
- E** Roscador.
- I** Filettatore.

4719.T



4719.R

GB Round starting head.

- D** Runder Führungskopf.
- F** Tête ronde.
- E** Cabeza redonda.
- I** Puntale tondo.

4719.R



4719.A

GB Adapter.

- D** Adapter.
- F** Manchon.
- E** Manguito.
- I** Manicotto.

4719.A

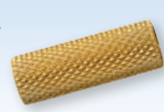

4719.M

GB Magnet.

- D** Magnet.
- F** Aimante.
- E** Imán.
- I** Calamita.

4719.M



4719.PE

GB Pulling eyelet with ring.

- D** Führungskopf mit Öse und Ring.
- F** Ogive initiale avec bague.
- E** Ogiva iniziale con anello.
- I** Ogiva iniziale con anello.

4719.PE



4719.C

GB Chain.

- D** Kette.
- F** Chainette.
- E** Cadenita.
- I** Catenina.

4719.C



4719.G

GB Glider.

- D** Gleitaufsatz.
- F** Tête glissant.
- E** Cabeza deslizando.
- I** Testa antiostacolo.

4719.G



4719.CPR1 / 4719.CPR2

GB Cable pulling grip.

- D** Kabelziehstrumpf.
- F** Chauette tracteurs.
- E** Malla tiracables.
- I** Calze tirafili.

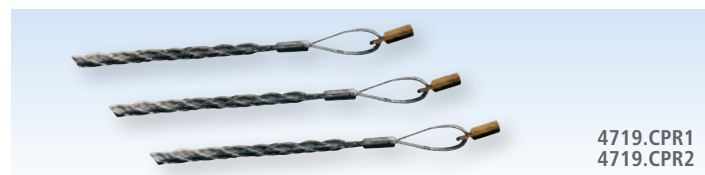

4719.CPR1
4719.CPR2

Item	Ø mm	L mm	Brake Load (kg)
4719.CPR1	6-9	200	220
4719.CPR2	9-12	250	440

- GB** Rod made of fiberglass covered with PP with interchangeable accessories M5.
- D** Glasfaserband mit PP-Ummantelung mit austauschbaren Endstücken M5.
- F** Tirefil avec âme en fibre de verre, revêtement en PP avec des terminaux interchangeable M5.
- E** Guía pasacable en fibra de vidrio recubierto de PP con punta intercambiable M5.
- I** Sonda passacavo in fibra di vetro rivestita in PP con accessori intercambiabili M5.



Item	Length	
FV310	10 m	20
FV315	15 m	10
FV320	20 m	10
FV325	25 m	5
FV330	30 m	5

- GB** Set up you like
Accessories and spare parts
- D** Montiere wie Du willst
Zubehör und Ersatzteile
- F** Composer come vous voulez
Accessoires et pièces de rechange
- E** Sortijelo come queres
Accesorios y piezas de repuestos
- I** Componila come vuoi
Accessori e pezzi di ricambio

101800.E

- GB** Roll device/storing box.
- D** Bandmagazin.
- F** Enrouleur pour sonde.
- E** Contenedor para guía.
- I** Contenitore avvolgitore.



Aspo 300

- GB** Vertical steel reel.
- D** Senkrechte Stahl-haspel.
- F** Enrouleur en acier vertical.
- E** Contenedor vertical de acero.
- I** Aspo avvolgitore in acciaio verticale.



101050

- GB** Flexible starting spinner M5.
- D** Flexible Federführungs Kopf mit Zugöse M5.
- F** Tête flexible avec oeillet M5.
- E** Punta flexible con ojal de tiro M5.
- I** Puntale flessibile con asola M5.



101024

- GB** Pulling eyelet M5.
- D** Kopf mit Zugöse M5.
- F** Embout avec oeillet M5.
- E** Punta ojal M5.
- I** Tirante con asola M5.



101023

- GB** Starting/Enditing joint, M5 thread.
- D** Anfangs/Endhülse M5.
- F** Douille fileté, M5.
- E** Casquillo roscado, M5.
- I** Terminale filettato, M5.



101027

- GB** Special glue 3 gr.
- D** Spezialkleber 3 gr.
- F** Colle spéciale 3 gr.
- E** Adhesivo para fibra 3 gr.
- I** Colla speciale 3 gr.

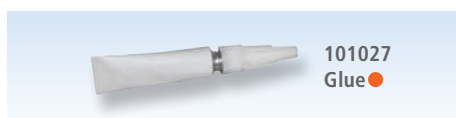

101025

- GB** Coupling joint.
- D** Verbindungshülse
- F** Douille de raccord
- E** Junta de conexion
- I** Giunto di riparazione



- GB** Rod made of fiberglass covered with PP with interchangeable accessories M5.
- D** Glasfaserband mit PP-Ummantelung mit austauschbaren Endstücken M5.
- F** Tirefil avec âme en fibre de verre, revêtement en PP avec des terminaux interchangeable M5.
- E** Guía pasacable en fibra de vidrio recubierto de PP con punta intercambiable M5.
- I** Sonda passacavo in fibra di vetro rivestita in PP con accessori intercambiabili M5.



Item	Length	
RFV4520	20 m	1
RFV4530	30 m	1
RFV4540	40 m	1

- GB** Set up you like
Accessories and spare parts
- D** Montiere wie Du willst
Zubehör und Ersatzteile
- F** Composer come vous voulez
Accessoires et pièces de rechange
- E** Sortijelo come queres
Accesorios y piezas de repuestos
- I** Componila come vuoi
Accessori e pezzi di ricambio

Aspo 300

- GB** Vertical steel reel.
- D** Senkrechte Stahl-haspel.
- F** Enrouleur en acier vertical.
- E** Contenedor vertical de acero.
- I** Aspo avvolgitore in acciaio verticale.



102010

- GB** Standard Starting spinner \varnothing 11 M5.
- D** Standard Federführungs Kopf mit Zugöse \varnothing 11 M5.
- F** Tête standard avec oeillet \varnothing 11 M5.
- E** Punta standard con ojal de tiro \varnothing 11 M5.
- I** Puntale standard con asola \varnothing 11 M5.



102011

- GB** Starting/Ending joint, M5 thread.
- D** Anfangs/Endhülse M5.
- F** Douille fileté, M5.
- E** Casquillo roscado, M5.
- I** Terminale filettato, M5.

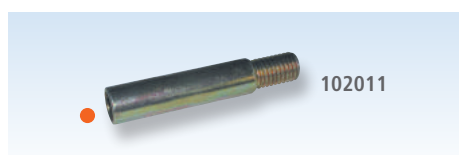

101028

- GB** Special glue 24 gr.
- D** Spezialkleber 24 gr.
- F** Colle spéciale 24 gr.
- E** Adhesivo para fibra 24 gr.
- I** Colla speciale 24 gr.

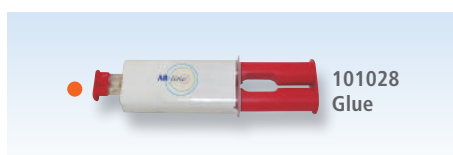

102009

- GB** Coupling joint.
- D** Verbindungshülse
- F** Douille de raccord
- E** Junta de conexion
- I** Giunto di riparazione





Polypropylene-Fiberglass \varnothing 4,5 mm



- GB** Rod made of fiberglass covered with PP with interchangeable accessories M5.
- D** Glasfaserband mit PP-Ummantelung mit austauschbaren Endstücken M5.
- F** Tirefil avec âme en fibre de verre, revêtement en PP avec des terminaux interchangeable M5.
- E** Guía pasacable en fibra de vidrio recubierto de PP con punta intercambiable M5.
- I** Sonda passacavo in fibra di vetro rivestita in PP con accessori intercambiabili M5.



Item	Length	
FVC4520	20 m	1
FVC4530	30 m	1
FVC4540	40 m	1

Item	Length	
FVC4550	50 m	1
FVC4560	60 m	1
FVC4570	70 m	1
FVC4580	80 m	1



Polypropylene-Fiberglass \varnothing 6 mm



- GB** Rod made of fiberglass covered with PP with interchangeable accessories M6.
- D** Glasfaserband mit PP-Ummantelung mit austauschbaren Endstücken M6.
- F** Tirefil avec âme en fibre de verre, revêtement en PP avec des terminaux interchangeable M6.
- E** Guía pasacable en fibra de vidrio recubierto de PP con punta intercambiable M6.
- I** Sonda passacavo in fibra di vetro rivestita in PP con accessori intercambiabili M6.



Item	Length	
FVC640	40 m	1
FVC650	50 m	1
FVC660	60 m	1
FVC670	70 m	1
FVC680	80 m	1
FVC6100	100 m	1

- GB** Fiberglass rod with coupling glued M6.
- D** Glasfaserband mit verklebten Anfangs-Endhülsen M6.
- F** Tirefil en fibre de verre avec terminalux collé M6.
- E** Guía pasacable en fibra de vidrio con punta M6 encolada.
- I** Sonda in fibra di vetro con terminali M6 incollati.



Item	Length	
RFV640	40 m	1
RFV650	50 m	1
RFV660	60 m	1
RFV670	70 m	1
RFV680	80 m	1
RFV6100	100 m	1

- GB** Set up you like
Accessories and spare parts
- D** Montiere wie Du willst
Zubehör und Ersatzteile
- F** Composer come vous voulez
Accessoires et pièces de rechange
- E** Sortijelo come queres
Accesorios y piezas de repuestos
- I** Componila come vuoi
Accessori e pezzi di ricambio

Aspo 600

- GB** Horizontal steel reel.
- D** Liegende stahl-haspel.
- F** Horizontal Enrouleur en acier.
- E** Contenedor horizontal de acero.
- I** Aspo avvolgitore orizzontale in acciaio.

Aspo 600



102012

- GB** Starting spinner M6.
- D** Federführungs Kopf mit Zugöse M6.
- F** Tête avec oeillet M6.
- E** Punta con ojal de tiro M6.
- I** Puntale con asola M6.

102012



103300

- GB** Starting spinner with shackle and M6 thread.
- D** Anfangsbirne M6 mit Schäkel.
- F** Embout M6 avec manille.
- E** Cabeza guía M6 con grillete de engancho.
- I** Ogiva iniziale M6 con grillo d'aggancio.

103300



103301

- GB** Starting roller made of aluminium alloy with M6 thread.
- D** Anfangsbirne Führungsrolle M6 aus Aluminium.
- F** Ogive M6 avec roues en aluminium
- E** Cabeza guía M6 con ruedas de aleacion ligera
- I** Ruota di scorrimento in alluminio M6.

103301



102013

- GB** Flexible starting spinner M6.
- D** Flexible Federführungs Kopf M6.
- F** Tête flexible M6.
- E** Punta flexible M6.
- I** Puntale flessibile M6.

102013

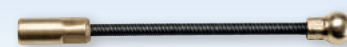

012

- GB** Starting joint, M6.
- D** Anfangshülse M6.
- F** Douille filetée, M6.
- E** Casquillo roscado, M6.
- I** Raccordo iniziale, M6.



101028

- GB** Special glue 24 gr.
- D** Spezialkleber 24 gr.
- F** Colle spéciale 24 gr.
- E** Adhesivo para fibra 24 gr.
- I** Colla speciale 24 gr.







103487

- GB** Coupling joint.
- D** Verbindungshülse
- F** Douille de raccord
- E** Junta de conexion
- I** Giunto di riparazione

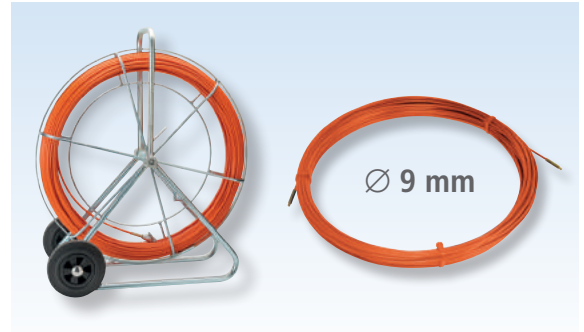

- GB** Rod made of fiberglass covered with PP with interchangeable accessories M12.
D Glasfaserband mit PP-Ummantelung mit austauschbaren Endstücken M12.
F Tirefil avec âme en fibre de verre, revêtement en PP avec des terminaux interchangeable M12.
E Guía pasacable en fibra de vidrio recubierto de PP con punta intercambiable M12.
I Sonda passacavo in fibra di vetro rivestita in PP con accessori intercambiabili M12.



 Item	Length		 Item
FVC960	60 m	1	RFV960
FVC980	80 m	1	RFV980
FVC9100	100 m	1	RFV9100
FVC9120	120 m	1	RFV9120
FVC9150	150 m	1	RFV9150

- GB** Accessories and spare parts **D** Zubehör und Ersatzteile **F** Accessoires et pièces de rechange **E** Accesorios y piezas de repuestos **I** Accessori e pezzi di ricambio

105000

- GB** Mechanical meter-counter.
D Mechanischer meterlähler.
F Compte-mètres mécanique.
E Contador de metros.
I Contometri meccanico.

105000

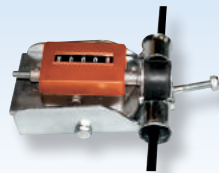

103207

- GB** Starting spinner M12.
D Anfangsbirne M12.
F Embout M12.
E Cabeza guía inicial M12.
I Puntale iniziale M12.

103207



103208

- GB** Starting spinner with shackle and M12 thread.
D Anfangsbirne M12 mit Schäkel.
F Embout M12 avec manille.
E Cabeza guía M12 con grillete de enganche.
I Ogiva iniziale M12 con grillo d'aggancio.

103208



103303

- GB** Starting roller made of aluminium alloy with M12 thread.
D Anfangsbirne Führungsrolle M12 aus Aluminium.
F Ogive M12 avec roues en aluminium
E Cabeza guía M12 con ruedas de aleacion ligera
I Ruota di scorrimento in alluminio M12.

103303



102057

- GB** Rotating joint connections M12.
D Verbindungshülse mit Drehwirbel M12.
F Accoupleur tournant M12.
E Manguito giratorio M12.
I Giunto snodato girevole M12.

102057



103200

- GB** Starting joint, M12.
D Anfangshülse M12.
F Douille filetée, M12.
E Casquillo roscado, M12.
I Raccordo iniziale, M12

103200



101028

- GB** Special glue 24 gr.
D Spezialkleber 24 gr.
F Colle spéciale 24 gr.
E Adhesivo para fibra 24 gr.
I Colla speciale 24 gr.

101028
Glue



103203



- GB** Coupling joint.
D Verbindungshülse
F Douille de raccord
E Junta de conexion
I Giunto di riparazione

103203

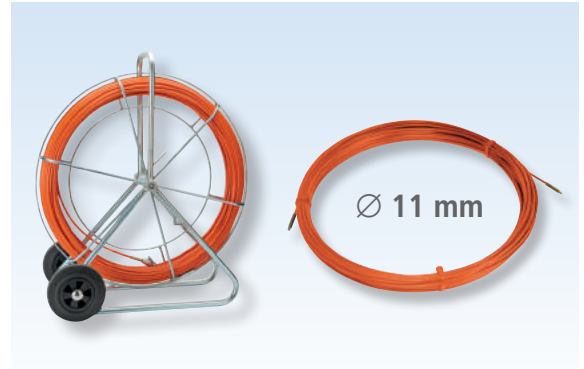

- GB** Rod made of fiberglass covered with PP with interchangeable accessories M12.
- D** Glasfaserband mit PP-Ummantelung mit austauschbaren Endstücken M12.
- F** Tirefil avec âme en fibre de verre, revêtement en PP avec des terminaux interchangeable M12.
- E** Guía pasacable en fibra de vidrio recubierto de PP con punta intercambiable M12.
- I** Sonda passacavo in fibra di vetro rivestita in PP con accessori intercambiabili M12.



 Item	Length		 Item
FVC11100	100 m	1	RFV11100
FVC11120	120 m	1	RFV11120
FVC11150	150 m	1	RFV11150
FVC11200	200 m	1	RFV11200
FVC11250	250 m	1	RFV11250
FVC11300	300 m	1	RFV11300

- GB** Accessories and spare parts
- D** Zubehör und Ersatzteile
- F** Accessoires et pièces de rechange
- E** Accesorios y piezas de repuestos
- I** Accessori e pezzi di ricambio

105000

- GB** Mechanical meter-counter.
- D** Mechanischer meterlähler.
- F** Compte-mètres mécanique.
- E** Contador de metros.
- I** Contometri meccanico.

105000

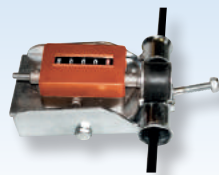

103207

- GB** Starting spinner M12.
- D** Anfangsbirne M12.
- F** Embout M12.
- E** Cabeza guía inicial M12.
- I** Puntale iniziale M12.

103207



103208

- GB** Starting spinner with shackle and M12 thread.
- D** Anfangsbirne M12 mit Schäkel.
- F** Embout M12 avec manille.
- E** Cabeza guía M12 con grillete de enganche.
- I** Ogiva iniziale M12 con grillo d'aggancio.

103208



103303

- GB** Starting roller made of aluminium alloy with M12 thread.
- D** Anfangsbirne Führungsrolle M12 aus Aluminium.
- F** Ogive M12 avec roues en aluminium
- E** Cabeza guía M12 con ruedas de aleacion ligera
- I** Ruota di scorrimento in alluminio M12.

103303



102057

- GB** Rotating joint connections M12.
- D** Verbindungshülse mit Drehwirbel M12.
- F** Accoupleur tournant M12.
- E** Manguito giratorio M12.
- I** Giunto snodato girevole M12.

102057



103202

- GB** Starting joint, M12.
- D** Anfangshülse M12.
- F** Douille filetée, M12.
- E** Casquillo roscado, M12.
- I** Raccordo iniziale, M12



103202

101028

- GB** Special glue 24 gr.
- D** Spezialkleber 24 gr.
- F** Colle spéciale 24 gr.
- E** Adhesivo para fibra 24 gr.
- I** Colla speciale 24 gr.



101028
Glue

103205

- GB** Coupling joint.
- D** Verbindungshülse
- F** Douille de raccord
- E** Junta de conexion
- I** Giunto di riparazione



103205

- GB** Rod made of fiberglass covered with PP with interchangeable accessories M12.
- D** Glasfaserband mit PP-Ummantelung mit austauschbaren Endstücken M12.
- F** Tirefil avec âme en fibre de verre, revêtement en PP avec des terminaux interchangeable M12.
- E** Guía pasacable en fibra de vidrio recubierto de PP con punta intercambiable M12.
- I** Sonda passacavo in fibra di vetro rivestita in PP con accessori intercambiabili M12.



Item	Length	
105250	250 m	1
105300	300 m	1
105350	350 m	1
105400	400 m	1
105450	450 m	1

- GB** Accessories and spare parts
- D** Zubehör und Ersatzteile
- F** Accessoires et pièces de rechange
- E** Accesorios y piezas de repuestos
- I** Accessori e pezzi di ricambio

105015

- GB** Mechanical meter-counter.
- D** Mechanischer meterlähler.
- F** Compte-mètres mécanique.
- E** Contador de metros.
- I** Contametri meccanico.

105015



105057

- GB** Rotating joint connections M12.
- D** Verbindungshülse mit Drehwirbel M12.
- F** Accoupleur tournant M12.
- E** Manguito giratorio M12.
- I** Giunto snodato girevole M12.

105057



103208

- GB** Starting spinner with shackle and M12 thread.
- D** Anfangsbirne M12 mit Schäkel.
- F** Embout M12 avec manille.
- E** Cabeza guía M12 con grillete de enganche.
- I** Ogiva iniziale M12 con grillo d'aggancio.

103208



103303

- GB** Starting roller made of aluminium alloy with M12 thread.
- D** Anfangsbirne Führungsrolle M12 aus Aluminium.
- F** Ogive M12 avec roues en aluminium
- E** Cabeza guía M12 con ruedas de aleacion ligera
- I** Ruota di scorrimento in alluminio M12.

103303



105209

- GB** Starting joint, M12.
- D** Anfangshülse M12.
- F** Douille filetée, M12.
- E** Casquillo roscado, M12.
- I** Raccordo iniziale, M12

101028

- GB** Special glue 24 gr.
- D** Spezialkleber 24 gr.
- F** Colle spéciale 24 gr.
- E** Adhesivo para fibra 24 gr.
- I** Colla speciale 24 gr.

105487

- GB** Coupling joint.
- D** Verbindungshülse
- F** Douille de raccord
- E** Junta de conexion
- I** Giunto di riparazione

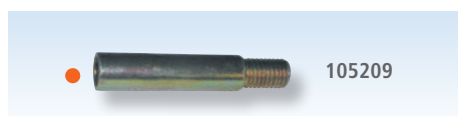

105209

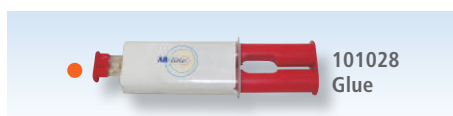

101028
Glue



105487

ABM15

- GB** Tripod mechanical cable drum lifter trestle. In strong steel structure, galvanized plated finish. Suitable for reels from \varnothing 1100÷1700 mm.
Load capacity: 1600 kg (with 2 pcs.)
Weight: 14 kg
- D** Gewindespindelheber für Kabeltrommeln, mechanisch, Stahlkonstruktion verzinkt. Für Trommeln mit Durchmesser von 1100÷1700 mm.
Tragkraft: 1600 kg (mit 2 Stück)
Gewicht: 14 kg
- F** Chevalet Mécanique en acier galvanisé pour lever les bobines. Pour bobines \varnothing 1100÷1700 mm.
Capacité de charge: 1600 kg (avec 2 pièces)
Poids: 14 kg
- E** Tripode elevador mecánico de bobina en acero galvanizado. Para bobina \varnothing 1100÷1700 mm.
Capacidad: 1600 kg (para 2 piezas)
Peso: 14 kg
- I** Cavalletto meccanico alzabobine in acciaio zincato. Per bobine con \varnothing 1100÷1700 mm.
Portata: 1600 kg (per 2 pezzi)
Peso: 14 kg



ABM15

sample

ABI16

- GB** Hydraulic cable drum lifter trestle. In strong steel structure, galvanized plated finish. Suitable for reels from \varnothing 1000÷1700 mm.
Load capacity: 1600 kg (with 2 pcs.)
Weight: 16 kg
- D** Hydraulischer, Kabeltrommelheber, Stahlkonstruktion verzinkt. Für Trommeln mit Durchmesser von 1000-1700 mm.
Tragkraft: 1600 kg (mit 2 Stück)
Gewicht: 16 kg
- F** Chevalet hydraulique en acier galvanisé pour lever les bobines. Pour bobines \varnothing 1000÷1700 mm.
Capacité de charge: 1600 kg (avec 2 pièces)
Poids: 16 kg
- E** Tripode elevador hidráulico de bobina en acero galvanizado. Para bobina \varnothing 1000÷1700 mm.
Capacidad: 1600 kg (para 2 piezas)
Peso: 16 kg
- I** Cavalletto idraulico alza bobine in acciaio zincato. Per bobine con \varnothing 1000÷1700 mm.
Portata: 1600 kg (per 2 pezzi)
Peso: 16 kg



ABI16

- GB** Special accessories and spare parts **D** Sonder-Zubehör und Ersatzteile **F** Accessoires spéciaux et pièces de rechange **E** Accesorios especiales y piezas de repuestos **I** Accessori speciali e pezzi di ricambio

AB6025

- GB** Tubular unwinding shaft in steel galvanized.
- D** Verzinkte Stahlrohrwelle \varnothing 60 mm.
- F** Arbre en acier zincado \varnothing 60 mm.
- E** Eje de acero zincado \varnothing 60 mm.
- I** Albero tubolare in acciaio zincato \varnothing 60 mm.



AB7025 - \varnothing 60 mm -1500 mm- max 1600 kg

AB6026

- GB** Galvanised steel collar.
- D** Verzinkte Stahlrohrwelle.
- F** Collier de blocage.
- E** Collar de fijación.
- I** Collare di fissaggio.



AB7026 - \varnothing 60 mm

AB6027

- GB** Steel centering cone for tubular.
- D** Feststellkonus aus Stahl.
- F** Collier de blocage en acier.
- E** Cono de sujecion.
- I** Cono di centraggio per bobina.

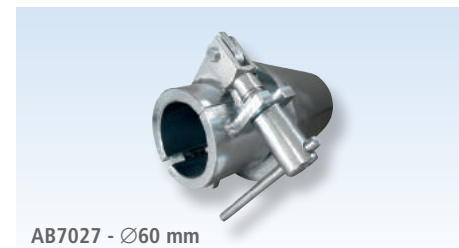

AB7027 - \varnothing 60 mm

ABI17 / ABI18 / ABI19 / ABI21

- GB** Strong Cable Drum lifter tresle with hydraulic foot-pump system and wheels.
- D** Hydraulischer Hebebock für Kabeltrommeln mit Fußpumpe.
- F** Chavalet hydraulique avec pompe à pied pour lever les bobines.
- E** Gato hidráulico de bobina con bomba de pie.
- I** Robusto cavalletto idraulico con pompa a pedale per sollevamento bobine.

Item	Load capacity/ Pair/Coppia	Weight/piece	Drum diameter
ABI17	1800 kg	32,65 kg	700-2000 mm
ABI18	3000 kg	53,15 kg	800-2500 mm
ABI19	5000 kg	75,55 kg	1000-3200 mm
ABI21	10000 kg	150,55 kg	1000-3600 mm



- GB** Special accessories and spare parts
- D** Sonder-Zubehör und Ersatzteile
- F** Accessoires spéciaux et pièces de rechange
- E** Accesorios especiales y piezas de repuestos
- I** Accessori speciali e pezzi di ricambio

AB7525

- GB** Galvanized Steel Drum axis.
- D** Trommelachse aus Verzinkte Stahl.
- F** Axe du tambour en acier.
- E** Eje tubular de acero zincado.
- I** Tubolare in acciaio zincato.

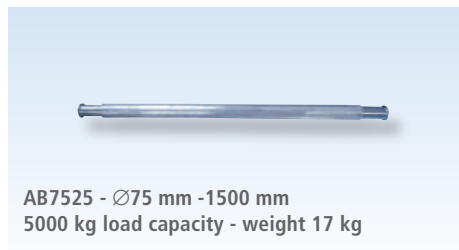

AB7526

- GB** Galvanised steel collar.
- D** Verzinkte Stahlrohrwelle.
- F** Collier de blocage.
- E** Collar de fijación.
- I** Collare di fissaggio.



AB7527

- GB** Steel centering cone for tubular.
- D** Feststellkonus aus Stahl.
- F** Collier de blocage en acier.
- E** Cono de sujecion.
- I** Cono di centraggio per bobina.



GSB28 / GSB29 / GSB30

- GB** Hook for lifting drums.
- D** Schnell Greifhaken für Kabeltrommeln.
- F** Crochet de levage pour les bobines.
- E** Gancho para elevación de bobinas.
- I** Gancio di sollevamento bobine.

Item	Drum hole diameter	Load capacity
GSB28	55 - 110 mm	1000 kg
GSB29	65 - 140 mm	2000 kg
GSB30	95 - 170 mm	5000 kg

GSB28 - Ø48 mm
GSB29 - Ø60 mm
GSB30 - Ø90 mm



PSB10

- GB** Set of unreeling devices with space bar. In strong steel structure galvanized plated finish, with unreeling rollers in aluminium.
- D** Kabeltrommeln-Abroller mit Distanzstab Stahlkonstruktion verzinkt mit Laufrollen in Aluminium.
- F** Système de déroulement pour bobines en acier galvanisé avec des rouleaux en aluminium.
- E** Sistema de rodadura para bobinas en acero galvanizado con rodillos en aluminio.
- I** Pattini di srotolamento con barra distanziatrice. In acciaio zincato e con rulli in alluminio

Reels Ø mm	Load capacity (kg)	Weight (kg)
400÷1200	1000	13,5



PSB20

- GB** Universal steel unwinding system
- D** Kabeltrommel-Abroller
- F** Systeme de déroulement pour bobines
- E** Sistema de rodadura para bobinas
- I** Svolgibobina

Reels Ø mm	Load capacity (kg)	Weight (kg)
200÷700	250	11

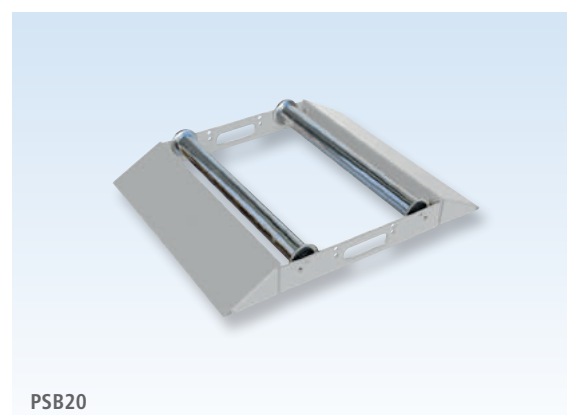

RG60 - RG63 - RG70 - RG18 - RG19 - RG20

- GB** Galvanized steel cable roller.
- D** Verzinkte Kabelverlegerolle.
- F** Roule au pose-cable.
- E** Rodillo de guía de cable.
- I** Rullo guidacavo.

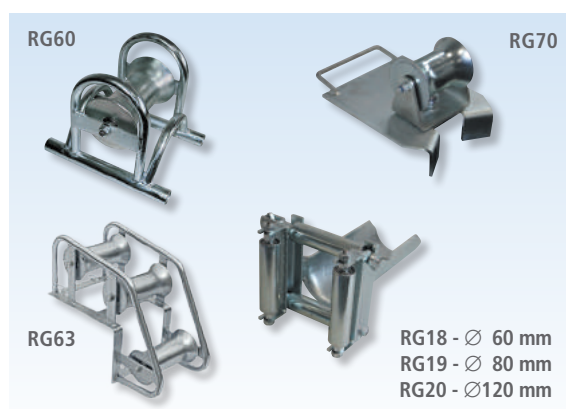

AT03 - AT06

- GB** Telescopic shaft.
- D** Verstellbare Spannachse.
- F** Barre télescopique.
- E** Eje ajustable.
- I** Asta telescopica.



Rapido 1

- GB** Suggested to remove the old cables and also to insert the new cables. Biodegradable and not toxic.
- D** Geeignet um die alten Kabel herauszuziehen und auch die neuen Kabel einzuziehen. Biologisch abbaubar und nicht toxisch.
- F** Raccomandé pour enlever les vieux câbles et d'insérer les nouveaux. Biodégradable et atoxique.
- E** Recomienda retirar los cables de edad y también para insertar el nuevo.
- I** Suggestito per rimuovere i vecchi cavi e anche per infilare i nuovi. Biodegradabile e non tossico



Rapido.1 (1 lt)

Rapido Gel

- GB** Lubricant Gel. Reduce 80% the friction effect during installation of electrical, telephone, fiber optic and coaxial cables.
- D** Gleitmittel Gel. 80% Reibungsreduzierend beim Einzug von Elektro, Telefon, Glasfaser und Koaxialkabel.
- F** Lubrifiant Gel. 80% réduit le frottement dans l'installation de câbles électriques, téléphoniques, fibres optiques et coaxiaux.
- E** Lubrificante Gel. 80% reduce la fricción durante la instalacion de cables eléctricos, telefónicos, de fibra óptica y coaxial.
- I** Gel lubrificante. Riduce dell'80% l'attrito durante la posa dei cavi elettrici, telefonici, fibra ottica e coassiali.



Rapido Gel.025 (250 ml)

Rapido Gel.1 (1 lt)

Rapido Spray

- GB** Spray foam. Reduce 70% the friction effect during installation of electrical, telephone, fiber optic and coaxial cables.
- D** Gleitmittel Schaumspritze. 70% Reibungsreduzierend beim Einzug von Elektro, Telefon, Glasfaser und Koaxialkabel.
- F** Mousse Spray. 70% réduit le frottement dans l'installation de câbles électriques, téléphoniques, fibres optiques et coaxiaux.
- E** Espuma Spray. 70% reduce la fricción durante la instalacion de cables eléctricos, telefónicos, de fibra óptica y coaxial.
- I** Schiuma Spray. Riduce dell'70% l'attrito durante la posa dei cavi elettrici, telefonici, fibra ottica e coassiali.



Rapido Spray.040 (400 ml)

Easyisogel

This is a high viscosity gel which, by effect of gravity, is able to take all spaces, hollows, gaps inside the container where it is placed. It is a ready for use product, non stick, non oily, and is transparent and odourless. Thanks to its special formula, Easyisogel is inert to temperature changes, to ageing and may be reused several times. It is self-agglomerating and has remarkable isolating power.

- Self-levelling - takes all spaces inside the container
- Self-agglomerating - does not need being amalgamated
- Ready for use - does not need mixing
- Reusable - does not solidify, does not decay
- Removable - at any time, even after years
- Non-toxic - it is not hazardous for humans, animals or the environment
- Dielectric - excellent isolating power: 15 kv
- Transparent - it lets you check the condition of connections at any time
- Non stick - it does not remain and does not soil surfaces

EASYISOGEL.05



Lay one portion of Easyisogel on the bottom of the box. Perform wiring.

Fill the box well with Easyisogel, without leaving any empty spaces.

Close the box cover.

Item	Description	
EASYISOGEL.05	500 gr can	4

- GB** Solid empty display with 8 hooks.
Set up as you like.
- D** Solide leerer Verkaufsständer mit 8 Haken. Montiere wie Du willst.
- F** Solid display avec 8 crochets.
Composer comme vous voulez.
- E** Solido espositor vacío con 8 ganchos.
Sortijelo como quieres.
- I** Solido espositore vuoto con 8 ganci.
Allestisci come vuoi.

Here Your brand
Hier Ihre Marke
Ici votre marque
Aquí su marca
Qui il vostro logo



Expo.1

- GB** Solid empty display with 6 hooks and 1 brackets.
Set up as you like.
- D** Solide leerer Verkaufsständer mit 6 Haken und 1 Konsole. Montiere wie Du willst.
- F** Solid display avec 6 crochets et 1 plateau.
Composer comme vous voulez.
- E** Solido espositor vacío con 6 ganchos y 1 repisa. Sortijelo como quieres.
- I** Solido espositore vuoto con 6 ganci e 1 mensola.
Allestisci come vuoi.

Here Your brand
Hier Ihre Marke
Ici votre marque
Aquí su marca
Qui il vostro logo



Expo.2

Hook for lifting drums
Scnell Greifhaken für Kabelatrommeln.
Crochet de levage pour les bobines.
Gancho para elevación de bobinas.
Gancio di sollevamento bobine.

Copyright © by ARLINE S.r.l.

- GB** All items photographed in the Catalogue are protected by intellectual right. Under no circumstances will any logo, trade mark and photograph be imprinted to any catalog and media or photocopy to third party without the permission of the legal owner. Any infringement of intellectual rights in structure patent, design and trade mark in the catalogue is a serious offence and all violator will be prosecuted.
- D** Alle Texte, Bilder und Grafiken in diesem Katalog unterliegen urheberrechtlichem Schutz. Wer Werke oder Werkteile dieser Seitennutzen möchte, soll sich bitte an den Urheber wenden.
- F** Tous droits réservés. La reproduction, meme partielle, est autorisée seulement du propriétaire des droits.
- E** Reservados todos los derechos. La reproducción incluso parcial está permitida solo después de la autorización del propietario de los derechos.
- I** È vietata la riproduzione parziale o totale del catalogo senza il preventivo consenso scritto del proprietario.

ORDINI	Le commissioni assunte dalle nostre Agenzie sono soggette all'approvazione della nostra direzione commerciale.
MODIFICHE	Ci riserviamo la facoltà di apportare, in qualsiasi momento e senza alcun preavviso, delle modifiche migliorative alle caratteristiche tecniche, estetiche, normative dei nostri prodotti.
QUANTITÀ MINIME	Quantità inferiori alle confezioni minime verranno automaticamente arrotondate alle stesse.
MINIMO D'ORDINE	Non verranno evasi ordini di importo inferiore a € 200,00 + I.V.A.
IMBALLO	Compreso
TRASPORTO	PORTO FRANCO per ordini oltre € 400,00 + I.V.A.; per ordini di importo inferiore, PORTO FRANCO con addebito di € 25,00 + I.V.A.; o PORTO ASSEGNATO a mezzo del corriere indicato dal cliente. In caso di indisponibilità parziale di materiale, il residuo d'ordine verrà evaso in porto franco se il relativo importo è superiore al minimo evadibile.
TERMINI DI CONSEGNA	i termini di consegna si intendono indicativi e non impegnativi. Ci riserviamo di cancellare, del tutto o in parte, articoli che, per qualsiasi ragione, non fossero disponibili, anche dopo l'accettazione della commissione. In nessun caso di ritardo delle spedizioni e delle consegne, l'acquirente può rifiutare la merce o chiedere indennizzi di qualsiasi tipo. La merce si intende venduta sempre franco nostro magazzino di Cinisello Balsamo e viaggia a rischio e pericolo dell'acquirente, anche se spedita in porto franco. Per eventuali contestazioni dovute a rotture o mancanze di colli, ritardi, avarie....., il cliente deve avvalersi esclusivamente nei confronti del corriere, all'atto della consegna, dandocene comunque comunicazione scritta per poter intervenire a suo favore.
RECLAMI	Qualsiasi reclamo deve, sotto pena di decadenza, essere proposto a mezzo lettera raccomandata da inviare alla ARLINE SRL entro il termine di 8 giorni dal ricevimento della merce.
RESI	Non si accetta merce di ritorno senza nostra autorizzazione scritta. Eventuali resi si intendono franco nostro magazzino. Per le modalità di autorizzazione al reso si prega di prendere contatto con l'agenzia di zona. Verrà respinto al mittente qualsiasi reso non espressamente da noi autorizzato.
PAGAMENTI	Nel caso di ritardo nei pagamenti concordati non verranno effettuate ulteriori forniture.
RISERVA DI PROPRIETÀ	La fornitura si intende fatta e accettata con il patto di riservato dominio fino al totale assolvimento degli obblighi di pagamento con noi assunti.
PREZZI	I nostri prezzi di vendita si intendono I.V.A. esclusa e non sono impegnativi. Potranno essere aumentati con particolare riferimento alla fluttuazione del costo delle materie prime di qualità e la difficoltà di reperimento delle stesse. L'acquirente riceverà preavviso scritto della variazione dei prezzi prima della nostra conferma d'ordine.

FORO COMPETENTE: ad ogni effetto si intende il foro di Milano.

**TUTTE LE CONDIZIONI DESCRITTE SONO ACCETTATE DAL CLIENTE,
ALL'ATTO DEL CONFERIMENTO DELL'ORDINE,
ANCHE SE NON ESPLICITAMENTE SOTTOSCRITTE.**

ARLINE

ARLINE S.r.l.

Via Pellizza da Volpedo, 57/59

20092 Cinisello Balsamo (MI) - ITALY

Tel. +39.02.61293094 - Fax +39.02.61461765

info@arline.it

www.arline.it