

Cable-Pulling Systems

Kabeleinzugsysteme

Tire-fils

Guías Pasacable

Sonde Passacavi

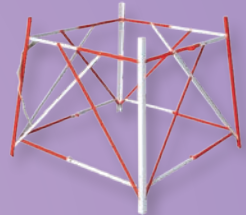
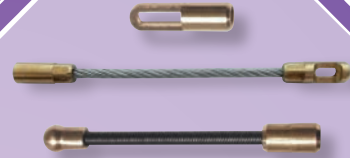

**ARLINE**

Manufacturers since 1944 - Hersteller seit 1944  
Fabrication depuis 1944 - Fabricación desde 1944  
Fabbrichiamo dal 1944



# Nylon $\varnothing$ 3 mm



- GB Draw-in tape with **fixed heads**.
- D Einziehband mit direkt **gepressten Endstücken**.
- F Tirefil avec des terminaux **fixes**.
- E Guía pasacable con **punta fija**.
- I Passacavo con **terminali fissi**.

Item	Length	
N305	5 m	150 / 20
N310	10 m	100 / 20
N315	15 m	80 / 20
N320	20 m	50 / 10
N325	25 m	40 / 10
N330	30 m	35 / 10

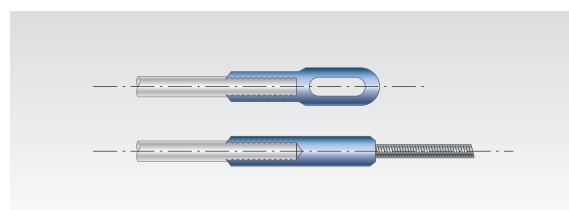

- GB White transparent (also available in the following colors).
- D Transparent Weiß (lieferbar auch in anderen Farben).
- F Blanc transparent (aussi disponible en les suivantes couleurs).
- E Blanco transparente (es tambien disponible en los siguientes colores).
- I Trasparente (disponibile nei seguenti colori).

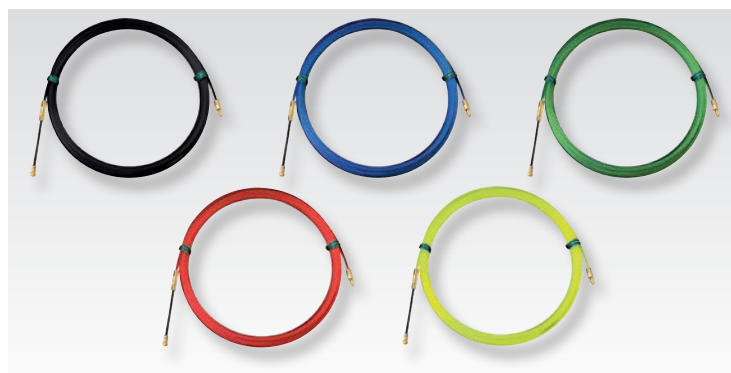

# PERLON<sup>®</sup> $\varnothing$ 3 mm



- GB Draw-in tape with **fixed heads**.
- D Einziehband mit direkt **gepressten Endstücken**.
- F Tirefil avec des terminaux **fixes**.
- E Guía pasacable con **punta fija**.
- I Passacavo con **terminali fissi**.

Item	Length	
A305	5 m	20
A310	10 m	20
A315	15 m	20
A320	20 m	10
A325	25 m	10
A330	30 m	10

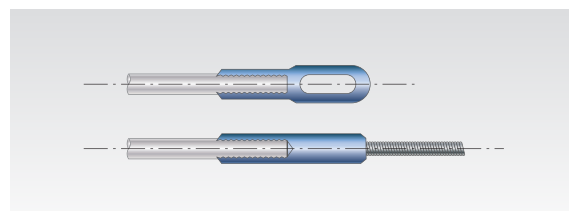

- GB** Draw-in tape with **interchangeable** accessories threaded directly on nylon.
- D** Einziehband mit **austauschbaren** Endstücken. Gewinde direkt auf Nylonstab.
- F** Tirefil avec des terminaux **interchangeables** filetés sur nylon.
- E** Guía pasacable con punta **intercambiable** roscado directamente en el nylon.
- I** Passacavo con accessori **intercambiabili**, filettati direttamente sul nylon.

Item N400	Item 5100	Length	
N405	5100.05	5 m	100 / 20
N410	5100.10	10 m	60 / 20
N415	5100.15	15 m	50 / 20
N420	5100.20	20 m	40 / 10
N425	5100.25	25 m	30 / 10
N430	5100.30	30 m	25 / 10

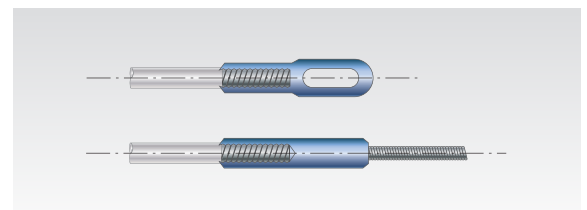

**GB** Spare parts

**D** Ersatzteile

**F** Pièces de rechange

**E** Piezas de repuestos

**I** Ricambi

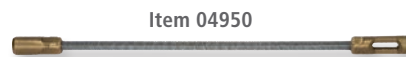

**GB** Draw-in tape with **fixed heads**.

**D** Einziehband mit direkt **gespressten Endstücken**.

**F** Tirefil avec des terminaux **fixes**.

**E** Guía pasacable con **punta fija**.

**I** Passacavo con **terminali fissi**.

Item N400F	Item 5100F	Length	
N405F	5100.05F	5 m	100
N410F	5100.10F	10 m	60
N415F	5100.15F	15 m	50
N420F	5100.20F	20 m	40
N425F	5100.25F	25 m	30
N430F	5100.30F	30 m	25

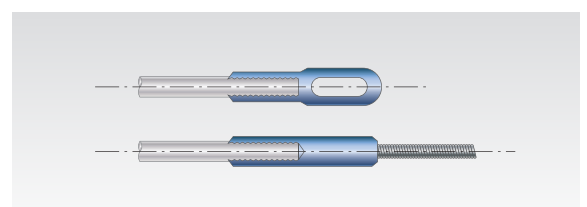

- GB** Draw-in tape with **interchangeable** accessories threaded directly on Perlon.
- D** Einziehband mit **austauschbaren** Endstücken. Gewinde direkt auf Perlonstab.
- F** Tirefil avec des terminaux **interchangeables** filetés sur Perlon.
- E** Guía pasacable con punta **intercambiable** roscado directamente en el Perlon.
- I** Passacavo con accessori **intercambiabili**, filettati direttamente sul filo Perlon.

Item	Length	
A405	5 m	20
A410	10 m	20
A415	15 m	20
A420	20 m	10
A425	25 m	10
A430	30 m	10

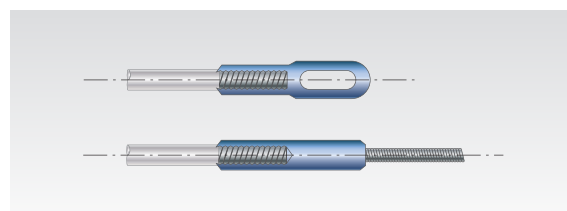

**GB** Spare parts

**D** Ersatzteile

**F** Pièces de rechange

**E** Piezas de repuestos

**I** Ricambi

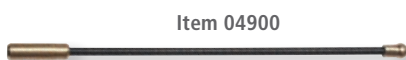

Item 04900

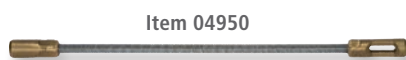

Item 04950



Item  
046 / GR



Item  
043

**GB** Draw-in tape with **interchangeable** accessories threaded on brass.

**D** Einziehband mit **austauschbaren** Endstücken. Gewinde auf Messing.

**F** Tirefil avec des terminaux **interchangeables** filetés sur laiton.

**E** Guía pasacable con punta **intercambiable** roscado en el latón.

**I** Passacavo con accessori **intercambiabili**, filettati su ottone.

Item	Length	
B405	5 m	20
B410	10 m	20
B415	15 m	20
B420	20 m	10
B425	25 m	10
B430	30 m	10

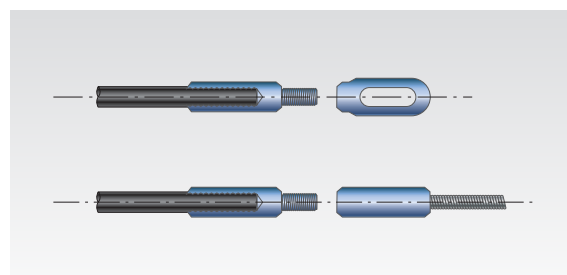

# Helicoidal Polyester $\varnothing$ 3 mm



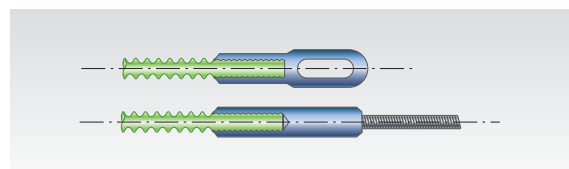
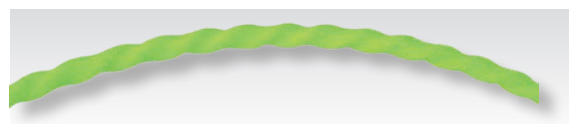

- GB** Polyester helicoidal monofilament rod with **fixed heads**. Friction reduced thanks to the halved contact surface.
- D** Schraubeförmige Kabeleinziehsonde aus Polyester Monofilament, reduziert Reibung. Mit **direct gepressten Endstücken**.
- F** Tirefil de polyester guipée monofilament, réduit la friction. Avec **terminaux fixes**.
- E** Guía pasacable monofilamento de poliéster helicoidal con **punta fija**. Por sus crestas helicoidales tiene menor resistencia a penetrar en el tubo.
- I** Sonda elicoidale in poliesterone monofilo con doppio **puntale fisso**. Riduce al minimo l'attrito perché la superficie di contatto è dimezzata.

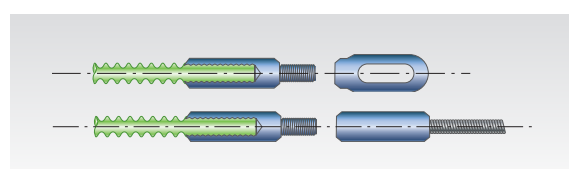

Item	Length	
PM0310F	10 m	5
PM0315F	15 m	5
PM0320F	20 m	5

- GB** Polyester helicoidal monofilament rod with **interchangeable** accessories M 3,5. Friction reduced thanks to the halved contact surface.
- D** Schraubeförmige Kabeleinziehsonde aus Polyester Monofilament, reduziert Reibung. Mit **austauschbaren Endstücken** M 3,5.
- F** Tirefil de polyester guipée monofilament, réduit la friction. Avec **terminaux interchangeable** M 3,5.
- E** Guía pasacable monofilamento de poliéster helicoidal con **punta intercambiable** M 3,5. Por sus crestas helicoidales tiene menor resistencia a penetrar en el tubo.
- I** Sonda elicoidale in poliesterone monofilo con accessori **intercambiabili** M 3,5. Riduce al minimo l'attrito perché la superficie di contatto è dimezzata.



Item	Length	
PM0310	10 m	5
PM0315	15 m	5
PM0320	20 m	5

**GB** Accessories and spare parts **D** Zubehör und Ersatzteile **F** Accessoires et pièces de rechange **E** Accesorios y piezas de repuestos **I** Accessori e pezzi di ricambio



# Helicoidal Polyester $\varnothing$ 4 mm



- GB** Polyester helicoidal monofilament rod with **interchangeable accessories M5**. Friction reduced thanks to the halved contact surface.
- D** Schraubeförmige Kabeleinziehsonde aus Polyester Monofilament, reduziert Reibung. **Mit austauschbaren Endstücken M5**.
- F** Tirefil de polyester guipée monofilament, réduit la friction. **Avec terminaux interchangeables M5**.
- E** Guía pasacable monofilamento de poliéster helicoidal **con punta intercambiable M5**. Por sus crestas helicoidales tiene menor resistencia a penetrar en el tubo.
- I** Sonda elicoidale in poliesterone monofilo **con accessori intercambiabili M5**. Riduce al minimo l'attrito perché la superficie di contatto è dimezzata.

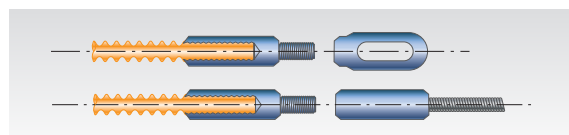
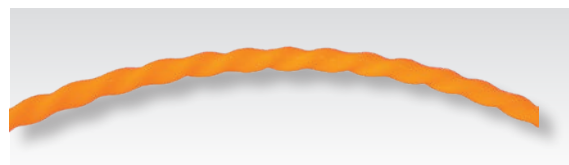

Item	Length	
PM4010	10 m	5
PM4015	15 m	5
PM4020	20 m	5
PM4025	25 m	5
PM4030	30 m	3

**GB** Accessories and spare parts

**D** Zubehör und Ersatzteile

**F** Accessoires et pièces de rechange

**E** Accesorios y piezas de repuestos

**I** Accessori e pezzi di ricambio



## CLZ

**GB** Cable pulling grip.

**D** Kabelziehstrumpf.

**F** Chauette tracteurs.

**E** Malla tiracables.

**I** Calze tirafili.

Item	$\varnothing$	L	Brake Load
CLZ4-6	4-6 mm	200 mm	215 kg
CLZ6-9	6-9 mm	210 mm	215 kg
CLZ9-12	9-12 mm	350 mm	450 kg
CLZ12-15	12-15 mm	350 mm	450 kg
CLZ15-19	15-19 mm	350 mm	1300 kg

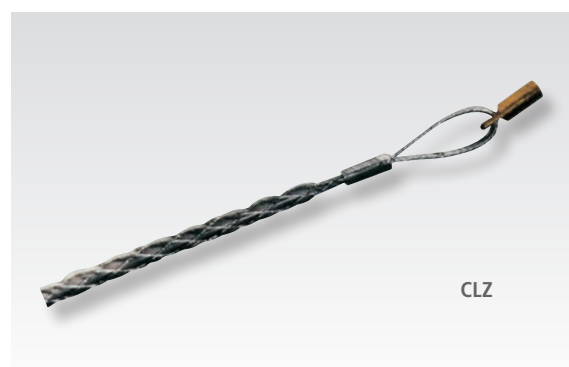

## Aspo 300

**GB** Vertical steel reel.

**D** Senkrechte Stahl-haspel.

**F** Enrouleur en acier vertical.

**E** Contenedor vertical de acero.

**I** Aspo avvolgitore in acciaio verticale.

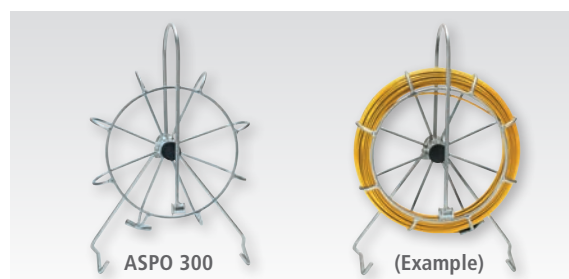

# Helicoidal Polyester $\varnothing$ 4,5 mm



- GB** Polyester helicoidal monofilament rod with **interchangeable accessories M5**. Friction reduced thanks to the halved contact surface.
- D** Schraubeförmige Kabeleinziehsonde aus Polyester Monofilament, reduziert Reibung. **Mit austauschbaren Endstücken M5**.
- F** Tirefil de polyester guipée monofilament, réduit la friction. **Avec terminaux interchangeables M5**.
- E** Guía pasacable monofilamento de poliéster helicoidal **con punta intercambiable M5**. Por sus crestas helicoidales tiene menor resistencia a penetrar en el tubo.
- I** Sonda elicoidale in poliesterone monofilo **con accessori intercambiabili M5**. Riduce al minimo l'attrito perché la superficie di contatto è dimezzata.

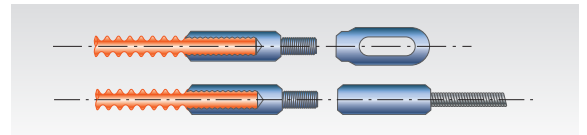
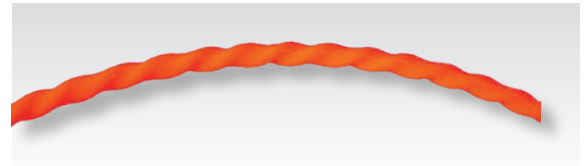

Item	Length	
PM4510	10 m	5
PM4515	15 m	5
PM4520	20 m	5
PM4525	25 m	5
PM4530	30 m	3

**GB** Accessories and spare parts

**D** Zubehör und Ersatzteile

**F** Accessoires et pièces de rechange

**E** Accesorios y piezas de repuestos

**I** Accessori e pezzi di ricambio

## CLZ

**GB** Cable pulling grip.

**D** Kabelziehstrumpf.

**F** Chauette tracteurs.

**E** Malla tiracables.

**I** Calze tirafili.

Item	$\varnothing$	L	Brake Load
CLZ4-6	4-6 mm	200 mm	215 kg
CLZ6-9	6-9 mm	210 mm	215 kg
CLZ9-12	9-12 mm	350 mm	450 kg
CLZ12-15	12-15 mm	350 mm	450 kg
CLZ15-19	15-19 mm	350 mm	1300 kg
CLZ19-25	19-25 mm	400 mm	1300 kg
CLZ25-31	25-31 mm	400 mm	1700 kg



## 450020 - 450010

**GB** Flexible starting spinner.

**D** Flexible Federführungs Kopf mit Zugöse.

**F** Tête flexible avec œillet.

**E** Punta flexible con ojal de tiro.

**I** Puntale flessibile con asola.

## Aspo 300

**GB** Vertical steel reel.

**D** Senkrechte Stahl-haspel.

**F** Enrouleur en acier vertical.

**E** Contenedor vertical de acero.

**I** Aspo avvolgitore in acciaio verticale.

## PGN

**GB** Pulling-pushing grip for  $\varnothing$  3-6 mm rod.

**D** Einziehhilfe für Kabeleinzugsystem  $\varnothing$  3-6 mm.

**F** Tirador para guía pasacables  $\varnothing$  3-6 mm.

**E** Poignée de tirage pour tire-fils  $\varnothing$  3-6 mm.

**I** Ganascia tira-sonde  $\varnothing$  3-6 mm.

## 072/5 - 130605 3/A

**GB** Pulling eyelet.

**D** Kopf mit Zugöse.

**F** Embout avec œillet.

**E** Punta ojal.

**I** Tirante con asola.

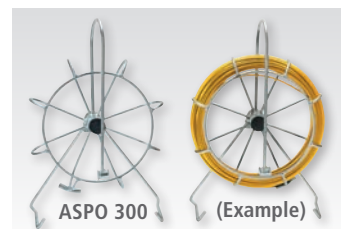
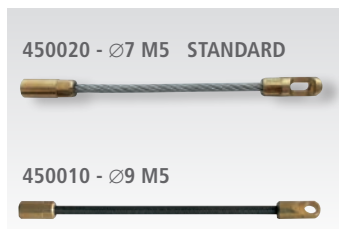

# Helicoidal Polyester $\varnothing$ 5 mm



**GB** Polyester helicoidal monofilament rod with **interchangeable accessories M5**. Friction reduced thanks to the halved contact surface.

**D** Schraubeförmige Kabeleinziehsonde aus Polyester Monofilament, reduziert Reibung. **Mit austauschbaren Endstücken M5.**

**F** Tirefil de polyester guipée monofilament, réduit la friction. **Avec terminaux interchangeables M5.**

**E** Guía pasacable monofilamento de poliéster helicoidal **con punta intercambiable M5**. Por sus crestas helicoidales tiene menor resistencia a penetrar en el tubo.

**I** Sonda elicoidale in poliesterone monofilo **con accessori intercambiabili M5**. Riduce al minimo l'attrito perché la superficie di contatto è dimezzata.

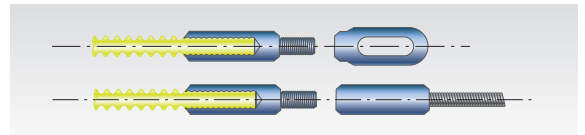

Item	Length	
PM5010	10 m	5
PM5015	15 m	5
PM5020	20 m	5
PM5025	25 m	5
PM5030	30 m	3
PM5040	40 m	1
PM5050	50 m	1

**GB** Accessories and spare parts

**D** Zubehör und Ersatzteile

**F** Accessoires et pièces de rechange

**E** Accesorios y piezas de repuestos

**I** Accessori e pezzi di ricambio

## CLZ

**GB** Cable pulling grip.

**D** Kabelziehstrumpf.

**F** Chauette tracteurs.

**E** Malla tiracables.

**I** Calze tirafili.

Item	$\varnothing$	L	Brake Load
CLZ4-6	4-6 mm	200 mm	215 kg
CLZ6-9	6-9 mm	210 mm	215 kg
CLZ9-12	9-12 mm	350 mm	450 kg
CLZ12-15	12-15 mm	350 mm	450 kg
CLZ15-19	15-19 mm	350 mm	1300 kg
CLZ19-25	19-25 mm	400 mm	1300 kg
CLZ25-31	25-31 mm	400 mm	1700 kg



## 450020 - 450010

**GB** Flexible starting spinner.

**D** Flexible Federführungs Kopf mit Zugöse.

**F** Tête flexible avec œillet.

**E** Punta flexible con ojal de tiro.

**I** Puntale flessibile con asola.

## Aspo 300

**GB** Vertical steel reel.

**D** Senkrechte Stahl-haspel.

**F** Enrouleur en acier vertical.

**E** Contenedor vertical de acero.

**I** Aspo avvolgitore in acciaio verticale.

## PGN

**GB** Pushing-Pulling grip.

**D** Einzieh hilfe.

**F** Poignée.

**E** Tirador para sonda pasacables.

**I** Tirasonda.

## 072/5 - 130605 3/A

**GB** Pulling eyelet.

**D** Kopf mit Zugöse.

**F** Embout avec œillet.

**E** Punta ojal.

**I** Tirante con asola.

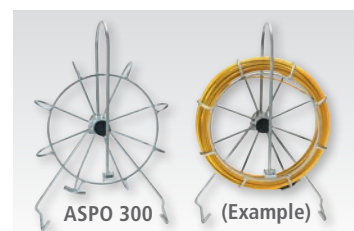
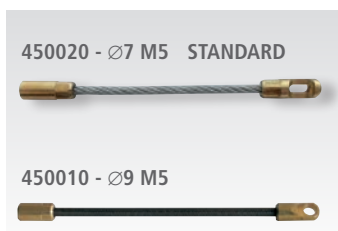

# Forte steel spiral $\varnothing$ 3 - 4,5 mm



- GB Draw-in tape with **fixed** heads.
- D Stahldraht Einziehband mit **gepressten** Endstücken.
- F Tirefil flexible en acier avec des terminaux **fixes**.
- E Guía flexible de acero con punta **fija**.
- I Sonda in trefolo di acciaio con terminali **fissi**.



**WARNING!** This is a tool only for professional use. Risk of electrical shock. For your safety **DO NOT USE** in ducts with voltage cables.  
**ATTENZIONE!** Rischio di shock elettrico **NON USARE** in tubi con presenza di cavi in tensione elettrica.

Item	Length	
2029.05	5 m	20
2029.10	10 m	20
2029.15	15 m	20
2029.20	20 m	10
2029.25	25 m	10
2029.30	30 m	10

Item	Length	
4029.05	5 m	20
4029.10	10 m	20
4029.15	15 m	20
4029.20	20 m	10
4029.25	25 m	10
4029.30	30 m	10



Item	Length	
4529.05	5 m	20
4529.10	10 m	20
4529.15	15 m	20
4529.20	20 m	10
4529.25	25 m	10
4529.30	30 m	10



# Polypropylene-steel wire $\varnothing$ 4 mm



- GB** Steel wire draw-in tape covered with PP, with **interchangeable** accessories M5.
- D** Stahldraht mit PP Ummantelung, mit **austauschbaren** Endstücken M5.
- F** Tirefil avec âme flexible en fil d'acier revêtement en PP. Avec des terminaux **interchangeables** M5.
- E** Guía pasacable con núcleo de hilo de acero recubierto de PP con punta **intercambiable** M5.
- I** Passacavo in filo d'acciaio ricoperto in PP. Accessori **intercambiabili** M5.



Item	Length	
4619.05	5 m	5
4619.10	10 m	5
4619.15	15 m	5
4619.20	20 m	5
4619.25	25 m	5
4619.30	30 m	5

 **WARNING!** This is a tool only for professional use. Risk of electrical shock. For your safety **DO NOT USE** in ducts with voltage cables. **ATTENZIONE!** Rischio di shock elettrico **NON USARE** in tubi con presenza di cavi in tensione elettrica.

**GB** Accessories and spare parts

**D** Zubehör und Ersatzteile

**F** Accessoires et pièces de rechange

**E** Accesorios y piezas de repuestos

**I** Accessori e pezzi di ricambio



## CLZ

**GB** Cable pulling grip.

**D** Kabelziehstrumpf.

**F** Chauette tracteurs.

**E** Malla tiracables.

**I** Calze tirafili.

Item	$\varnothing$	L	Brake Load
CLZ4-6	4-6 mm	200 mm	215 kg
CLZ6-9	6-9 mm	210 mm	215 kg
CLZ9-12	9-12 mm	350 mm	450 kg
CLZ12-15	12-15 mm	350 mm	450 kg
CLZ15-19	15-19 mm	350 mm	1300 kg



## Aspo 300

**GB** Vertical steel reel.

**D** Senkrechte Stahl-haspel.

**F** Enrouleur en acier vertical.

**E** Contenedor vertical de acero.

**I** Aspo avvolgitore in acciaio verticale.

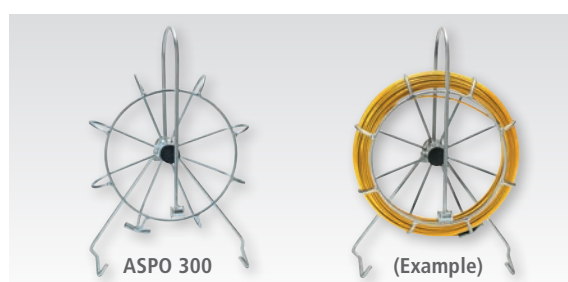

# Polypropylene-steel flat $\varnothing$ 4 mm



- GB** Rod made of flat steel covered with PP, with **interchangeable** accessories M5.
- D** Flachstahl Einziehband mit PP Ummantelung, mit **austauschbaren** Endstücken M5.
- F** Tirefil avec âme plate en acier, revêtement en PP avec des terminaux **interchangeable** M5.
- E** Guía pasacable en fleje acero recubierto de PP con punta **intercambiable** M5.
- I** Sonda passacavo in acciaio piatto rivestito in PP con accessori **intercambiabili** M5.

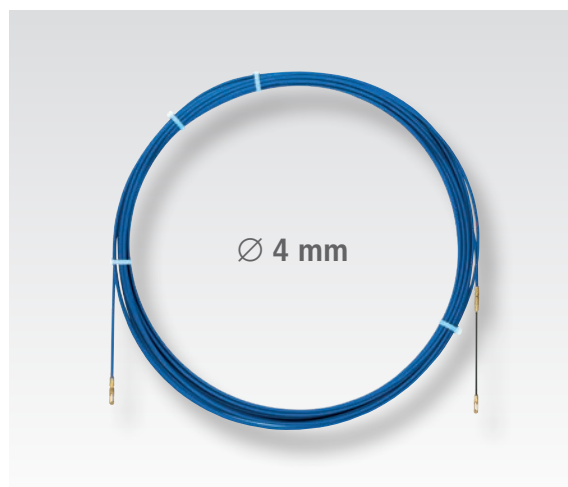

Item	Length	
0419.10	10 m	5
0419.15	15 m	5
0419.20	20 m	5
0419.25	25 m	5



**WARNING!** This is a tool only for professional use. Risk of electrical shock. For your safety **DO NOT USE** in ducts with voltage cables. **ATTENZIONE!** Rischio di shock elettrico **NON USARE** in tubi con presenza di cavi in tensione elettrica.

**GB** Accessories and spare parts

**D** Zubehör und Ersatzteile

**F** Accessoires et pièces de rechange

**E** Accesorios y piezas de repuestos

**I** Accessori e pezzi di ricambio



## CLZ

**GB** Cable pulling grip.

**D** Kabelziehstrumpf.

**F** Chauette tracteurs.

**E** Malla tiracables.

**I** Calze tirafili.

Item	$\varnothing$	L	Brake Load
CLZ4-6	4-6 mm	200 mm	215 kg
CLZ6-9	6-9 mm	210 mm	215 kg
CLZ9-12	9-12 mm	350 mm	450 kg
CLZ12-15	12-15 mm	350 mm	450 kg
CLZ15-19	15-19 mm	350 mm	1300 kg



## Aspo 300

**GB** Vertical steel reel.

**D** Senkrechte Stahl-haspel.

**F** Enrouleur en acier vertical.

**E** Contenedor vertical de acero.

**I** Aspo avvolgitore in acciaio verticale.

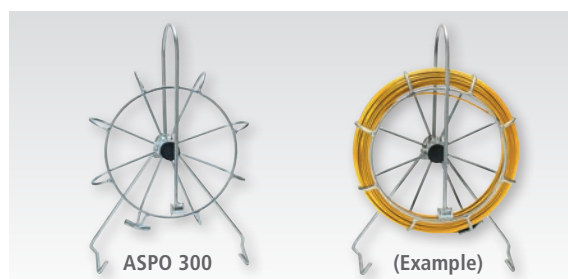

- GB** Rod made of flat steel covered with PP, with **interchangeable** accessories M5.
- D** Flachstahl Einziehband mit PP Ummantelung, mit **austauschbaren** Endstücken M5.
- F** Tirefil avec âme plate en acier, revêtement en PP avec des terminaux **interchangeable** M5.
- E** Guía pasacable en fleje acero recubierto de PP con punta **intercambiable** M5.
- I** Sonda passacavo in acciaio piatto rivestito in PP con accessori **intercambiabili** M5.

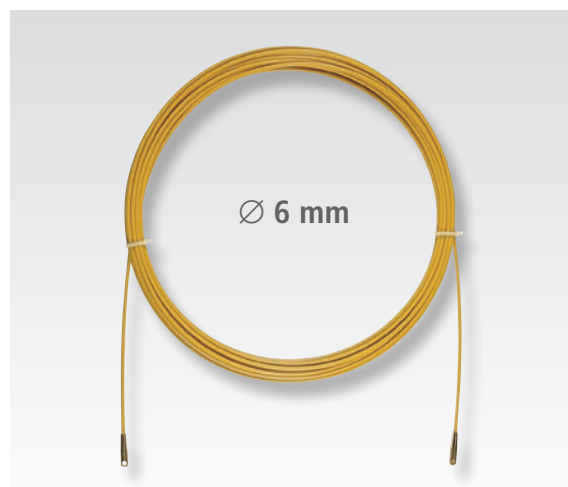

Item	Length	
AR620	20 m	5 / 1
AR630	30 m	5 / 1
AR640	40 m	5 / 1
AR650	50 m	5 / 1
AR660	60 m	5 / 1

 **WARNING!** This is a tool only for professional use. Risk of electrical shock. For your safety **DO NOT USE** in ducts with voltage cables. **ATTENZIONE!** Rischio di shock elettrico **NON USARE** in tubi con presenza di cavi in tensione elettrica.

**GB** Accessories and spare parts **D** Zubehör und Ersatzteile **F** Accessoires et pièces de rechange **E** Accesorios y piezas de repuestos **I** Accessori e pezzi di ricambio

## 064/B (STANDARD x 2 Pcs.)

- GB** Standard Starting spinner,  $\varnothing$  11 mm - M5.
- D** Standard Federführungs Kopf mit Zugöse,  $\varnothing$  11 mm - M5.
- F** Tête standard avec œillet,  $\varnothing$  11 mm - M5.
- E** Punta standard con ojal de tiro,  $\varnothing$  11 mm - M5.
- I** Puntale standard con asola,  $\varnothing$  11 mm - M5.

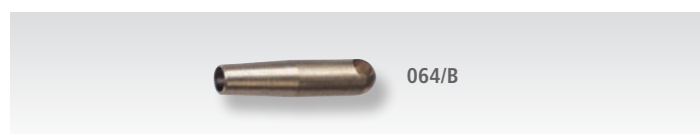

## AR697

- GB** Starting roller for AR691.
- D** Führungsrolle für AR691.
- F** Roue pour AR691.
- E** Ruedas para AR691.
- I** Ruota di scorrimento per AR691.

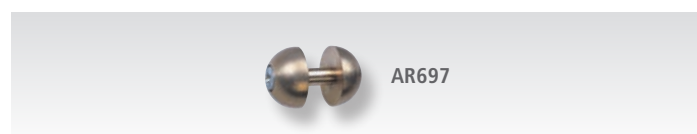

## AR695

- GB** Flexible starting spinner,  $\varnothing$  10 mm - M5.
- D** Flexible Federführungs Kopf,  $\varnothing$  10 mm - M5.
- F** Tête flexible,  $\varnothing$  10 mm - M5.
- E** Punta flexible,  $\varnothing$  10 mm - M5.
- I** Puntale flessibile,  $\varnothing$  10 mm - M5.



## Aspo 600

- GB** Horizontal steel reel.
- D** Liegende Stahl-haspel.
- F** Horizontal Enrouleur en acier.
- E** Contenedor horizontal de acero.
- I** Aspo avvolgitore orizzontale in acciaio.



- GB** Rod made of flat steel covered with PP, with **interchangeable** accessories M5.
- D** Flachstahl Einziehband mit PP Ummantelung, mit **austauschbaren** Endstücken M5.
- F** Tirefil avec âme plate en acier, revêtement en PP avec des terminaux **interchangeable** M5.
- E** Guía pasacable en fleje acero recubierto de PP con punta **intercambiable** M5.
- I** Sonda passacavo in acciaio piatto rivestito in PP con accessori **intercambiabili** M5.



Item	Length	
AR1040	40 m	1
AR1050	50 m	1
AR1060	60 m	1



**WARNING!** This is a tool only for professional use. Risk of electrical shock. For your safety **DO NOT USE** in ducts with voltage cables.  
**ATTENZIONE!** Rischio di shock elettrico **NON USARE** in tubi con presenza di cavi in tensione elettrica.

- GB** Special accessories and spare parts
- D** Sonder-Zubehör und Ersatzteile
- F** Accessoires spéciaux et pièces de rechange
- E** Accesorios especiales y piezas de repuestos
- I** Accessori speciali e pezzi di ricambio

## 103/B (STANDARD x 2 Pcs.)

- GB** Standard Starting spinner  $\varnothing$  20 mm - M5.
- D** Standard Federführungs Kopf mit Zugöse  $\varnothing$  20 mm - M5.
- F** Tête standard avec œillet.  $\varnothing$  20 mm - M5.
- E** Punta standard con ojal de tiro  $\varnothing$  20 mm - M5.
- I** Puntale standard con asola  $\varnothing$  20 mm - M5.



103 / B

## 103304

- GB** Special starting roller  $\varnothing$  50 mm - M5.
- D** Anfangsrolle  $\varnothing$  50 mm - M5.
- F** Ogive M5 avec rove  $\varnothing$  50 mm - M5.
- E** Cabeza guía M5 rueda  $\varnothing$  50 mm - M5.
- I** Puntale M5 con ruota  $\varnothing$  50 mm - M5.



103304

## Aspo 800

- GB** Vertical steel reel.
- D** Senkerechte Stahl-haspel.
- F** Enrouleur en acier vertical.
- E** Contenedor vertical de acero.
- I** Aspo avvolgitore in acciaio verticale.



ASPO 800  
( $\varnothing$  790 mm - 15 kg)

**GB** Arrow Rod is the right professional Tool for Electricians in installations in floating floors, in false ceiling, in empty walls and where are not available cable ducts. Arrow Rod is in fiber glass Ø 6 mm and give the best flexibility and at the same time the best resistance. Arrow Rod Set will be essential in electrical installation. To facilitate using of the components, it comes in a flexible strong tube.

**D** Schubstange aus verstärktem Glasfaserverbundstoff. Es ist die Lösung für die Kabelverlegung Zwischendecken, Hohlböden und Kabelkanäle.

**F** Tige de poussée en fibre de verre, c'est la solution pour l'installation de câbles dans les faux plafonds, planchers flottants et canalisés externe.

**E** Varilla de empuje en fibra de vidrio, Es la solución para la instalación de cables en falsos techos, tarimas flotantes y canales exteriores.

**I** Asta di spinta in fibra di vetro, la soluzione ideale per pavimenti galleggianti, pareti mobili e controsoffitti.

Item 4719.10.E Set composed by:

10 Pcs. Rod Ø 6 - 1m.

1 pc. Round flexible starting head

1 Pc. Pulling eyelet

1Pc. Pulling eyelet with ring

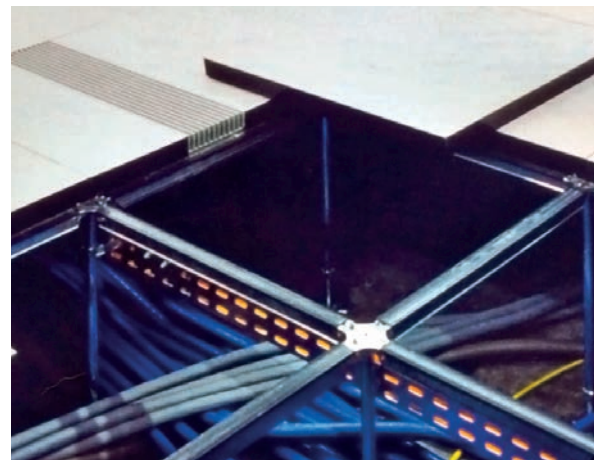
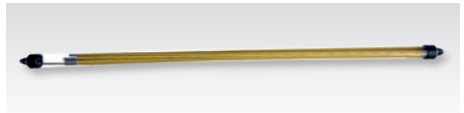
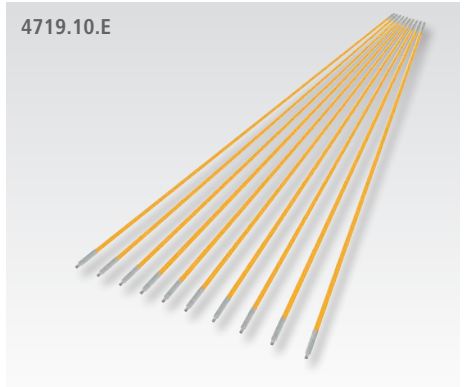

**GB** Special accessories and spare parts

**D** Sonder-Zubehör und Ersatzteile

**F** Accessoires spéciaux et pièces de rechange

**E** Accesorios especiales y piezas de repuestos

**I** Accessori speciali e pezzi di ricambio

## 101050

**GB** Flexible starting spinner M5.

**D** Flexible Federführungskopf mit Zugöse M5.

**F** Tête flexible avec œillet M5.

**E** Punta flexible con ojal de tiro M5.

**I** Puntale flessibile con asola M5.

## 101024

**GB** Pulling eyelet M5.

**D** Kopf mit Zugöse M5.

**F** Embout avec œillet M5.

**E** Punta ojal M5.

**I** Tirante con asola M5.

## 4719.PE

**GB** Pulling eyelet with ring.

**D** Führungskopf mit Öse und Ring.

**F** Ogive initiale avec bague.

**E** Cabeza guía con grillete de enganche.

**I** Ogiva iniziale con anello.



## CLZ

**GB** Cable pulling grip.

**D** Kabelziehstrumpf.

**F** Chauette tracteurs.

**E** Malla tiracables.

**I** Calze tirafili.

Item	Ø	L	Brake Load
CLZ4-6	4-6 mm	200 mm	215 kg
CLZ6-9	6-9 mm	210 mm	215 kg
CLZ9-12	9-12 mm	350 mm	450 kg
CLZ12-15	12-15 mm	350 mm	450 kg
CLZ15-19	15-19 mm	350 mm	1300 kg
CLZ19-25	19-25 mm	400 mm	1300 kg
CLZ25-31	25-31 mm	400 mm	1700 kg



- GB** Rod made of fiberglass covered with PP, with interchangeable accessories M5.  
**D** Glasfaserband mit PP-Ummantelung mit austauschbaren Endstücken M5.  
**F** Tirefil avec âme en fibre de verre, revêtement en PP avec des terminaux interchangeable M5.  
**E** Guía pasacable en fibra de vidrio recubierto de PP con punta intercambiable M5.  
**I** Sonda passacavo in fibra di vetro rivestita in PP con accessori intercambiabili M5.

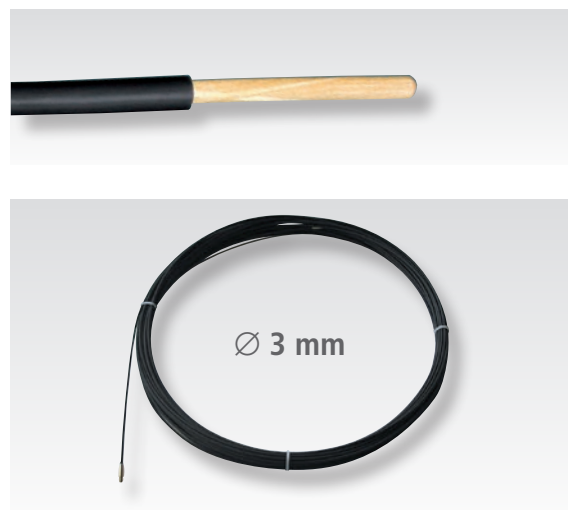

Item	Length	
FV310	10 m	20
FV315	15 m	10
FV320	20 m	10
FV325	25 m	5
FV330	30 m	5

- GB** Set up as you like  
Accessories and spare parts  
**D** Montiere wie Du willst  
Zubehör und Ersatzteile  
**F** Composer come vous voulez  
Accessoires et pièces de rechange  
**E** Sortijelo come quieres  
Accesorios y piezas de repuestos  
**I** Componila come vuoi  
Accessori e pezzi di ricambio

## 101800.E

- GB** Roll device/storing box.  
**D** Bandmagazin.  
**F** Enrouleur pour sonde.  
**E** Contenedor para guía.  
**I** Contenitore avvolgitore.

## Aspo 300

- GB** Vertical steel reel.  
**D** Senkrechte Stahl-haspel.  
**F** Enrouleur en acier vertical.  
**E** Contenedor vertical de acero.  
**I** Aspo avvolgitore in acciaio verticale.

## 101050

- GB** Flexible starting spinner M5.  
**D** Flexible Federführungskopf mit Zugöse M5.  
**F** Tête flexible avec œillet M5.  
**E** Punta flexible con ojal de tiro M5.  
**I** Puntale flessibile con asola M5.

## PGN

- GB** Pulling-pushing grip for  $\varnothing$  3-6 mm rod.  
**D** Einziehhilfe für Kabeleinzugsystem  $\varnothing$  3-6 mm.  
**F** Tirador para guía pasacables  $\varnothing$  3-6 mm.  
**E** Poignée de tirage pour tire-fils  $\varnothing$  3-6 mm.  
**I** Ganascia tira-sonde  $\varnothing$  3-6 mm.

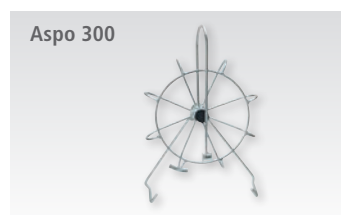

## CLZ

- GB** Cable pulling grip.  
**D** Kabelziehtrumpf.  
**F** Chauette tracteurs.  
**E** Malla tiracables.  
**I** Calze tirafili.

Item	$\varnothing$	L	Brake Load
CLZ4-6	4-6 mm	200 mm	215 kg
CLZ6-9	6-9 mm	210 mm	215 kg
CLZ9-12	9-12 mm	350 mm	450 kg
CLZ12-15	12-15 mm	350 mm	450 kg
CLZ15-19	15-19 mm	350 mm	1300 kg
CLZ19-25	19-25 mm	400 mm	1300 kg
CLZ25-31	25-31 mm	400 mm	1700 kg



## 101023

- GB** Starting/Ending joint, M5 thread.  
**D** Anfangs/Endhülse M5.  
**F** Douille filetée, M5.  
**E** Casquillo roscado, M5.  
**I** Terminale filettato, M5.

## 101027

- GB** Special glue 3 gr.  
**D** Spezialkleber 3 gr.  
**F** Colle spéciale 3 gr.  
**E** Adhesivo para fibra 3 gr.  
**I** Colla speciale 3 gr.

## 101025



- GB** Coupling joint.  
**D** Verbindungshülse.  
**F** Douille de raccord.  
**E** Junta de conexion.  
**I** Giunto di riparazione.

## 101024

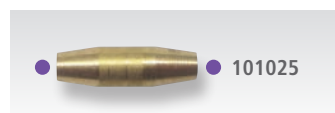
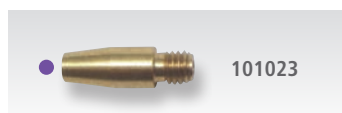
- GB** Pulling eyelet M5.  
**D** Kopf mit Zugöse M5.  
**F** Embout avec œillet M5.  
**E** Punta ojal M5.  
**I** Tirante con asola M5.



- GB** Rod made of fiberglass covered with PP, with interchangeable accessories M5.
- D** Glasfaserband mit PP-Ummantelung mit austauschbaren Endstücken M5.
- F** Tirefil avec âme en fibre de verre, revêtement en PP avec des terminaux interchangeable M5.
- E** Guía pasacable en fibra de vidrio recubierto de PP con punta intercambiable M5.
- I** Sonda passacavo in fibra di vetro rivestita in PP con accessori intercambiabili M5.

	Item	Length	
	FVC4520	20 m	1
	FVC4530	30 m	1
	FVC4540	40 m	1



Item	Length	
FVC4550	50 m	1
FVC4560	60 m	1
FVC4570	70 m	1
FVC4580	80 m	1



# Polypropylene-Fiberglass $\varnothing$ 4,5 mm

- GB** Rod made of fiberglass covered with PP, with interchangeable accessories M5.
- D** Glasfaserband mit PP-Ummantelung mit austauschbaren Endstücken M5.
- F** Tirefil avec âme en fibre de verre, revêtement en PP avec des terminaux interchangeable M5.
- E** Guía pasacable en fibra de vidrio recubierto de PP con punta intercambiable M5.
- I** Sonda passacavo in fibra di vetro rivestita in PP con accessori intercambiabili M5.



Item	Length	
RFV4520	20 m	1
RFV4530	30 m	1
RFV4540	40 m	1
RFV4550	50 m	1
RFV4560	60 m	1
RFV4570	70 m	1
RFV4580	80 m	1

- GB** Set up you like Accessories and spare parts
- D** Montiere wie Du willst Zubehör und Ersatzteile
- F** Composer come vous voulez Accessoires et pièces de rechange
- E** Sortijelo come quieres Accesorios y piezas de repuestos
- I** Componila come vuoi Accessori e pezzi di ricambio

## CLZ

**GB** Cable pulling grip.

**D** Kabelziehstrumpf.

**F** Chauette tracteurs.

**E** Malla tiracables.

**I** Calze tirafili.

Item	$\varnothing$	L	Brake Load
CLZ4-6	4-6 mm	200 mm	215 kg
CLZ6-9	6-9 mm	210 mm	215 kg
CLZ9-12	9-12 mm	350 mm	450 kg
CLZ12-15	12-15 mm	350 mm	450 kg
CLZ15-19	15-19 mm	350 mm	1300 kg
CLZ19-25	19-25 mm	400 mm	1300 kg
CLZ25-31	25-31 mm	400 mm	1700 kg



## Aspo 300

**GB** Vertical steel reel.

**D** Senkrechte Stahl-haspel.

**F** Enrouleur en acier vertical.

**E** Contenedor vertical de acero.

**I** Aspo avvolgitore in acciaio verticale.

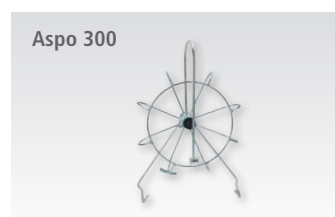

## PGN

**GB** Pulling-pushing grip for  $\varnothing$  3-6 mm rod.

**D** Einziehhilfe für Kabeleinzugsystem  $\varnothing$  3-6 mm.

**F** Tirador para guía pasacables  $\varnothing$  3-6 mm.

**E** Poignée de tirage pour tire-fils  $\varnothing$  3-6 mm.

**I** Ganascia tira-sonde  $\varnothing$  3-6 mm.



## 102011

**GB** Starting/Ending joint, M5 thread.

**D** Anfangs/Endhülse M5.

**F** Douille filettée, M5.

**E** Casquillo roscado, M5.

**I** Terminale filettato, M5.

## 101028

**GB** Special glue 24 gr.

**D** Spezialkleber 24 gr.

**F** Colle spéciale 24 gr.

**E** Adhesivo para fibra 24 gr.

**I** Colla speciale 24 gr.

## 102009

**GB** Coupling joint.

**D** Verbindungshülse.

**F** Douille de raccord.

**E** Junta de conexión.

**I** Giunto di riparazione.

## 102010

**GB** Standard Starting spinner  $\varnothing$  11 M5.

**D** Standard Federführungs Kopf mit Zugöse  $\varnothing$  11 M5.

**F** Tête standard avec œillet  $\varnothing$  11 M5.

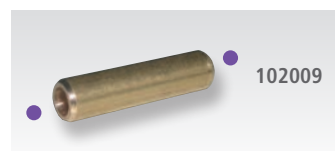

**E** Punta standard con ojal de tiro  $\varnothing$  11 M5.

**I** Puntale standard con asola  $\varnothing$  11 M5.



- GB** Rod made of fiberglass covered with PP, with interchangeable accessories M6.
- D** Glasfaserband mit PP-Ummantelung mit austauschbaren Endstücken M6.
- F** Tirefil avec âme en fibre de verre, revêtement en PP avec des terminaux interchangeable M6.
- E** Guía pasacable en fibra de vidrio recubierto de PP con punta intercambiable M6.
- I** Sonda passacavo in fibra di vetro rivestita in PP con accessori intercambiabili M6.



 Item	Length		 Item
FVC640	40 m	1	RFV640
FVC650	50 m	1	RFV650
FVC660	60 m	1	RFV660
FVC670	70 m	1	RFV670
FVC680	80 m	1	RFV680
FVC6100	100 m	1	RFV6100

- GB** Set up as you like  
Accessories and spare parts
- D** Montiere wie Du willst  
Zubehör und Ersatzteile
- F** Composer come vous voulez  
Accessoires et pièces de rechange
- E** Sortijelo come quieres  
Accesorios y piezas de repuestos
- I** Componila come vuoi  
Accessori e pezzi di ricambio

## Aspo 600

- GB** Horizontal steel reel.
- D** Liegende Stahl-haspel.
- F** Horizontal Enrouleur en acier.
- E** Contenedor horizontal de acero.
- I** Aspo avvolgitore orizzontale in acciaio.



## 102012

- GB** Starting spinner M6.
- D** Federführungs Kopf mit Zugöse M6.
- F** Tête avec œillet M6.
- E** Punta con ojal de tiro M6.
- I** Puntale con asola M6.

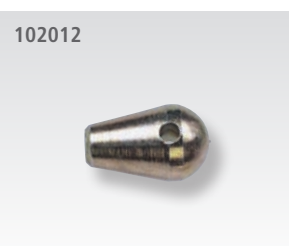

## 103300

- GB** Starting spinner with shackle and M6 thread.
- D** Anfangsbirne M6 mit Schäkel.
- F** Embout M6 avec manille.
- E** Cabeza guía M6 con grillete de enganche.
- I** Ogiva iniziale M6 con grillo d'aggancio.



## 103301

- GB** Starting roller made of aluminium alloy with M6 thread.
- D** Anfangsbirne Führungsrolle M6 aus Alluminium.
- F** Ogive M6 avec roues en aluminium
- E** Cabeza guía M6 con ruedas de aleacion ligera
- I** Ruota di scorrimento in alluminio M6.



## 102013

- GB** Flexible starting spinner M6.
- D** Flexible Federführungs Kopf M6.
- F** Tête flexible M6.
- E** Punta flexible M6.
- I** Puntale flessibile M6.



## 012

- GB** Starting joint, M6.
- D** Anfangshülse M6.
- F** Douille filetée, M6.
- E** Casquillo roscado, M6.
- I** Raccordo iniziale, M6.



## 101028

- GB** Special glue 24 gr.
- D** Spezialkleber 24 gr.
- F** Colle spéciale 24 gr.
- E** Adhesivo para fibra 24 gr.
- I** Colla speciale 24 gr.



## 103487



- GB** Coupling joint.
- D** Verbindungshülse.
- F** Douille de raccord.
- E** Junta de conexion.
- I** Giunto di riparazione.



- GB** Rod made of fiberglass covered with PP, with interchangeable accessories M6.
- D** Glasfaserband mit PP-Ummantelung mit austauschbaren Endstücken M6.
- F** Tirefil avec âme en fibre de verre, revêtement en PP avec des terminaux interchangeable M6.
- E** Guía pasacable en fibra de vidrio recubierto de PP con punta intercambiable M6.
- I** Sonda passacavo in fibra di vetro rivestita in PP con accessori intercambiabili M6.



FVC6 VSR

 Item	Length		 Item
FVC640 VSR	40 m	1	RFV640
FVC650 VSR	50 m	1	RFV650
FVC660 VSR	60 m	1	RFV660
FVC670 VSR	70 m	1	RFV670
FVC680 VSR	80 m	1	RFV680
FVC6100 VSR	100 m	1	RFV6100



RFV6

- GB** Set up as you like  
Accessories and spare parts
- D** Montiere wie Du willst  
Zubehör und Ersatzteile
- F** Composer come vous voulez  
Accessoires et pièces de rechange
- E** Sortijelo come quieres  
Accesorios y piezas de repuestos
- I** Componila come vuoi  
Accessori e pezzi di ricambio

## Aspo 600 VSR

- GB** Vertical steel reel.
- D** Senkrechte Stahl-haspel.
- F** Enrouleur en acier vertical.
- E** Contenedor vertical de acero.
- I** Aspo avvolgitore in acciaio verticale.



Aspo 600 VSR

## 102012

- GB** Starting spinner M6.
- D** Federführungs Kopf mit Zugöse M6.
- F** Tête avec œillet M6.
- E** Punta con ojal de tiro M6.
- I** Puntale con asola M6.

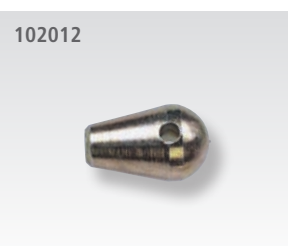

102012

## 103300

- GB** Starting spinner with shackle and M6 thread.
- D** Anfangsbirne M6 mit Schäkel.
- F** Embout M6 avec manille.
- E** Cabeza guía M6 con grillete de enganche.
- I** Ogiva iniziale M6 con grillo d'aggancio.



103300

## 103301

- GB** Starting roller made of aluminium alloy with M6 thread.
- D** Anfangsbirne Führungsrolle M6 aus Aluminium.
- F** Ogive M6 avec roues en aluminium
- E** Cabeza guía M6 con ruedas de aleacion ligera
- I** Ruota di scorrimento in alluminio M6.



103301

## 102013

- GB** Flexible starting spinner M6.
- D** Flexible Federführungs Kopf M6.
- F** Tête flexible M6.
- E** Punta flexible M6.
- I** Puntale flessibile M6.



102013

## 012

- GB** Starting joint, M6.
- D** Anfangshülse M6.
- F** Douille filetée, M6.
- E** Casquillo roscado, M6.
- I** Raccordo iniziale, M6.



012

## 101028

- GB** Special glue 24 gr.
- D** Spezialkleber 24 gr.
- F** Colle spéciale 24 gr.
- E** Adhesivo para fibra 24 gr.
- I** Colla speciale 24 gr.



101028  
Glue

## 103487

- GB** Coupling joint.
- D** Verbindungshülse.
- F** Douille de raccord.
- E** Junta de conexion.
- I** Giunto di riparazione.





103487

- GB** Rod made of fiberglass covered with PP, with interchangeable accessories M6.
- D** Glasfaserband mit PP-Ummantelung mit austauschbaren Endstücken M6.
- F** Tirefil avec âme en fibre de verre, revêtement en PP avec des terminaux interchangeable M6.
- E** Guía pasacable en fibra de vidrio recubierto de PP con punta intercambiable M6.
- I** Sonda passacavo in fibra di vetro rivestita in PP con accessori intercambiabili M6.



FVC6 VCR



 Item	Length		 Item
FVC640 VCR	40 m	1	RFV640
FVC650 VCR	50 m	1	RFV650
FVC660 VCR	60 m	1	RFV660
FVC670 VCR	70 m	1	RFV670
FVC680 VCR	80 m	1	RFV680
FVC6100 VCR	100 m	1	RFV6100



RFV6

- GB** Set up as you like  
Accessories and spare parts
- D** Montiere wie Du willst  
Zubehör und Ersatzteile
- F** Composer come vous voulez  
Accessoires et pièces de rechange
- E** Sortijelo come quieres  
Accesorios y piezas de repuestos
- I** Componila come vuoi  
Accessori e pezzi di ricambio

## Aspo 600 VCR

- GB** Vertical steel reel.
- D** Senkerechte Stahl-haspel.
- F** Enrouleur en acier vertical.
- E** Contenedor vertical de acero.
- I** Aspo avvolgitore in acciaio verticale.



Aspo 600 VCR

## 102012

- GB** Starting spinner M6.
- D** Federführungs Kopf mit Zugöse M6.
- F** Tête avec œillet M6.
- E** Punta con ojal de tiro M6.
- I** Puntale con asola M6.

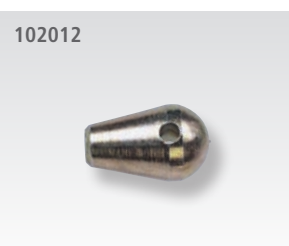

102012

## 103300

- GB** Starting spinner with shackle and M6 thread.
- D** Anfangsbirne M6 mit Schäkel.
- F** Embout M6 avec manille.
- E** Cabeza guía M6 con grillete de enganche.
- I** Ogiva iniziale M6 con grillo d'aggancio.



103300

## 103301

- GB** Starting roller made of aluminium alloy with M6 thread.
- D** Anfangsbirne Führungsrolle M6 aus Aluminium.
- F** Ogive M6 avec roues en aluminium
- E** Cabeza guía M6 con ruedas de aleacion ligera
- I** Ruota di scorrimento in alluminio M6.



103301

## 102013

- GB** Flexible starting spinner M6.
- D** Flexible Federführungs Kopf M6.
- F** Tête flexible M6.
- E** Punta flexible M6.
- I** Puntale flessibile M6.



102013

## 012

- GB** Starting joint, M6.
- D** Anfangshülse M6.
- F** Douille filetée, M6.
- E** Casquillo roscado, M6.
- I** Raccordo iniziale, M6.



012

## 101028

- GB** Special glue 24 gr.
- D** Spezialkleber 24 gr.
- F** Colle spéciale 24 gr.
- E** Adhesivo para fibra 24 gr.
- I** Colla speciale 24 gr.



101028  
Glue

## 103487

- GB** Coupling joint.
- D** Verbindungshülse.
- F** Douille de raccord.
- E** Junta de conexion.
- I** Giunto di riparazione.

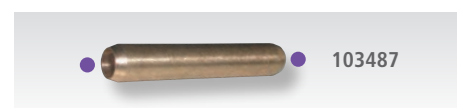

103487



- GB** Rod made of fiberglass covered with PP, with interchangeable accessories M12.  
**D** Glasfaserband mit PP-Ummantelung mit austauschbaren Endstücken M12.  
**F** Tirefil avec âme en fibre de verre, revêtement en PP avec des terminaux interchangeable M12.  
**E** Guía pasacable en fibra de vidrio recubierto de PP con punta intercambiable M12.  
**I** Sonda passacavo in fibra di vetro rivestita in PP con accessori intercambiabili M12.



FVC9



RFV9

 Item	Length		 Item
FVC960	60 m	1	RFV960
FVC980	80 m	1	RFV980
FVC9100	100 m	1	RFV9100
FVC9120	120 m	1	RFV9120
FVC9150	150 m	1	RFV9150

- GB** Accessories and spare parts **D** Zubehör und Ersatzteile **F** Accessoires et pièces de rechange **E** Accesorios y piezas de repuestos **I** Accessori e pezzi di ricambio

## 105000

- GB** Mechanical meter-counter.  
**D** Mechanischer Meterzähler.  
**F** Compte-mètres mécanique.  
**E** Contador de metros.  
**I** Contometri meccanico.



105000

## 103207

- GB** Starting spinner M12.  
**D** Anfangsbirne M12.  
**F** Embout M12.  
**E** Cabeza guía inicial M12.  
**I** Puntale iniziale M12.



103207

## 103208

- GB** Starting spinner with shackle and M12 thread.  
**D** Anfangsbirne M12 mit Schäkkel.  
**F** Embout M12 avec manille.  
**E** Cabeza guía M12 con grillete de enganche.  
**I** Ogiva iniziale M12 con grillo d'aggancio.



103208

## 103303

- GB** Starting roller made of aluminium alloy with M12 thread.  
**D** Anfangsbirne Führungsrolle M12 aus Aluminium.  
**F** Ogive M12 avec roues en aluminium.  
**E** Cabeza guía M12 con ruedas de aleación ligera.  
**I** Ruota di scorrimento in alluminio M12.



103303

## 102057

- GB** Rotating joint connections M12.  
**D** Verbindungshülse mit Drehwirbel M12.  
**F** Accoupleur tournant M12.  
**E** Manguito giratorio M12.  
**I** Giunto snodato girevole M12.



102057

## 103200

- GB** Starting joint, M12.  
**D** Anfangshülse M12.  
**F** Douille filetée, M12.  
**E** Casquillo roscado, M12.  
**I** Raccordo iniziale, M12.



103200

## 101028

- GB** Special glue 24 gr.  
**D** Spezialkleber 24 gr.  
**F** Colle spéciale 24 gr.  
**E** Adhesivo para fibra 24 gr.  
**I** Colla speciale 24 gr.



101028  
Glue

## 103203

- GB** Coupling joint.  
**D** Verbindungshülse.  
**F** Douille de raccord.  
**E** Junta de conexión.  
**I** Giunto di riparazione.



103203

- GB** Rod made of fiberglass covered with PP, with interchangeable accessories M12.
- D** Glasfaserband mit PP-Ummantelung mit austauschbaren Endstücken M12.
- F** Tirefil avec âme en fibre de verre, revêtement en PP avec des terminaux interchangeable M12.
- E** Guía pasacable en fibra de vidrio recubierto de PP con punta intercambiable M12.
- I** Sonda passacavo in fibra di vetro rivestita in PP con accessori intercambiabili M12.



Item	Length		Item
FVC11100	100 m	1	RFV11100
FVC11120	120 m	1	RFV11120
FVC11150	150 m	1	RFV11150
FVC11200	200 m	1	RFV11200
FVC11250	250 m	1	RFV11250
FVC11300	300 m	1	RFV11300

- GB** Accessories and spare parts **D** Zubehör und Ersatzteile **F** Accessoires et pièces de rechange **E** Accesorios y piezas de repuestos **I** Accessori e pezzi di ricambio

## 105000

- GB** Mechanical meter-counter.
- D** Mechanischer Meterzähler.
- F** Compte-mètres mécanique.
- E** Contador de metros.
- I** Contometri meccanico.



## 103207

- GB** Starting spinner M12.
- D** Anfangsbirne M12.
- F** Embout M12.
- E** Cabeza guía inicial M12.
- I** Puntale iniziale M12.



## 103208

- GB** Starting spinner with shackle and M12 thread.
- D** Anfangsbirne M12 mit Schäkkel.
- F** Embout M12 avec manille.
- E** Cabeza guía M12 con grillete de enganche.
- I** Ogiva iniziale M12 con grillo d'aggancio.



## 103303

- GB** Starting roller made of aluminium alloy with M12 thread.
- D** Anfangsbirne Führungsrolle M12 aus Aluminium.
- F** Ogive M12 avec roues en aluminium.
- E** Cabeza guía M12 con ruedas de aleación ligera.
- I** Ruota di scorrimento in alluminio M12.



## 102057

- GB** Rotating joint connections M12.
- D** Verbindungshülse mit Drehwirbel M12.
- F** Accoupleur tournant M12.
- E** Manguito giratorio M12.
- I** Giunto snodato girevole M12.



## 103202

- GB** Starting joint, M12.
- D** Anfangshülse M12.
- F** Douille filetée, M12.
- E** Casquillo roscado, M12.
- I** Raccordo iniziale, M12.



## 101028

- GB** Special glue 24 gr.
- D** Spezialkleber 24 gr.
- F** Colle spéciale 24 gr.
- E** Adhesivo para fibra 24 gr.
- I** Colla speciale 24 gr.



## 103205

- GB** Coupling joint.
- D** Verbindungshülse.
- F** Douille de raccord.
- E** Junta de conexión.
- I** Giunto di riparazione.



- GB** Rod made of fiberglass covered with PP, with interchangeable accessories M12.
- D** Glasfaserband mit PP-Ummantelung mit austauschbaren Endstücken M12.
- F** Tirefil avec âme en fibre de verre, revêtement en PP avec des terminaux interchangeable M12.
- E** Guía pasacable en fibra de vidrio recubierto de PP con punta intercambiable M12.
- I** Sonda passacavo in fibra di vetro rivestita in PP con accessori intercambiabili M12.



Item	Length	
105250	250 m	1
105300	300 m	1
105350	350 m	1
105400	400 m	1
105450	450 m	1

**GB** Accessories and spare parts **D** Zubehör und Ersatzteile **F** Accessoires et pièces de rechange **E** Accesorios y piezas de repuestos **I** Accessori e pezzi di ricambio

## 105015

- GB** Mechanical meter-counter.
- D** Mechanischer Meterzähler.
- F** Compte-mètres mécanique.
- E** Contador de metros.
- I** Contametri meccanico.



## 105057

- GB** Rotating joint connections M12.
- D** Verbindungshülse mit Drehwirbel M12.
- F** Accoupleur tournant M12.
- E** Manguito giratorio M12.
- I** Giunto snodato girevole M12.



## 103208

- GB** Starting spinner with shackle and M12 thread.
- D** Anfangsbirne M12 mit Schäkkel.
- F** Embout M12 avec manille.
- E** Cabeza guía M12 con grillete de enganche.
- I** Ogiva iniziale M12 con grillo d'aggancio.



## 103303

- GB** Starting roller made of aluminium alloy with M12 thread.
- D** Anfangsbirne Führungsrolle M12 aus Alluminium.
- F** Ogive M12 avec roues en aluminium.
- E** Cabeza guía M12 con ruedas de aleacion ligera.
- I** Ruota di scorrimento in alluminio M12.



## 105209

- GB** Starting joint, M12.
- D** Anfangshülse M12.
- F** Douille filetée, M12.
- E** Casquillo roscado, M12.
- I** Raccordo iniziale, M12.



## 101028

- GB** Special glue 24 gr.
- D** Spezialkleber 24 gr.
- F** Colle spéciale 24 gr.
- E** Adhesivo para fibra 24 gr.
- I** Colla speciale 24 gr.



## 105487

- GB** Coupling joint.
- D** Verbindungshülse.
- F** Douille de raccord.
- E** Junta de conexion.
- I** Giunto di riparazione.



## ABM05 / ABM15

- GB** Tripod mechanical cable drum lifter trestle. In strong steel structure, galvanized plated finish.
- D** Gewindespindelheber für Kabeltrommeln, mechanisch, Stahlkonstruktion verzinkt.
- F** Chevalet Mécanique en acier galvanisé pour lever les bobines.
- E** Tripode elevador mecanico de bobina en acero galvanizado.
- I** Cavalletto meccanico alzabobine in acciaio zincato.

Item	Load capacity/ Pair/Coppia	Weight/piece	Drum diameter	Dimensions L - W - H
ABM05	500 kg	3,7 kg	Ø 600-900 mm	220x140x365/535 mm
ABM15	1600 kg	14 kg	Ø 1100-1700 mm	400x200x635/945 mm



## ABI16

- GB** Hydraulic cable drum lifter trestle. In strong steel structure, galvanized plated finish. Suitable for reels from Ø 1000÷1700 mm. Load capacity: 1600 kg (with 2 pcs.). Weight: 16 kg. Dimension: 400x200x610 / 870 mm.
- D** Hydraulischer, Kabeltrommelheber, Stahlkonstruktion verzinkt. Für Trommeln mit Durchmesser von Ø 1000-1700 mm. Tragkraft: 1600 kg (mit 2 Stück). Gewicht: 16 kg. Abmessung: 400x200x610 / 870 mm.
- F** Chevalet hydraulique en acier galvanisé pour lever les bobines. Pour bobines Ø 1000÷1700 mm. Capacité de charge: 1600 kg (avec 2 pièces). Poids: 16 kg. Dimensions: 400x200x610 / 870 mm.
- E** Tripode elevador hidráulico de bobina en acero galvanizado. Para bobina Ø 1000÷1700 mm. Capacidad: 1600 kg (para 2 piezas). Peso: 16 kg. Dimensiones: 400x200x610 / 870 mm.
- I** Cavalletto idraulico alza bobine in acciaio zincato. Per bobine con Ø 1000÷1700 mm. Portata: 1600 kg (per 2 pezzi). Peso: 16 kg. Dimensioni: 400x200x610 / 870 mm.



- GB** Special accessories and spare parts
- D** Sonder-Zubehör und Ersatzteile
- F** Accessoires spéciaux et pièces de rechange
- E** Accesorios especiales y piezas de repuestos
- I** Accessori speciali e pezzi di ricambio

## AB6025

- GB** Tubular unwinding shaft in steel galvanized.
- D** Verzinkte Stahlrohrwelle Ø 60 mm.
- F** Arbre en acier Ø 60 mm.
- E** Eje de acero zincado Ø 60 mm.
- I** Albero tubolare in acciaio zincato Ø 60 mm.

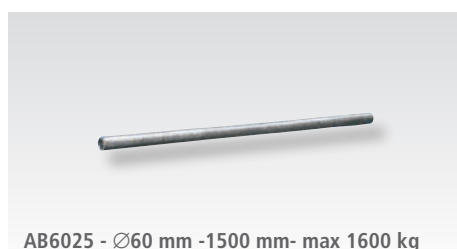

AB6025 - Ø60 mm -1500 mm- max 1600 kg

## AB6026

- GB** Galvanized steel collar.
- D** Verzinkte Stahlrohrwelle.
- F** Collier de blocage.
- E** Coliar de fijación.
- I** Collare di fissaggio.



AB6026 - Ø60 mm - 1,90 kg

## AB6027

- GB** Steel centering cone for tubular.
- D** Feststellkonus aus Stahl.
- F** Collier de blocage en acier.
- E** Cono de sujecion.
- I** Cono di centraggio per bobina.



AB6027 - Ø60 mm - 3 kg

## ABI17 / ABI18 / ABI19 / ABI21

- GB** Strong Cable Drum lifter trestle with hydraulic foot-pump system and wheels.
- D** Hydraulischer Hebebock für Kabeltrommeln mit Fußpumpe.
- F** Chavalet hydraulique avec pompe à pied pour lever les bobines.
- E** Gato hidráulico de bobina con bomba de pie.
- I** Robusto cavalletto idraulico con pompa a pedale per sollevamento bobine.

Item	Load capacity/ Pair/Coppia	Weight/piece	Drum diameter	Dimensions L - W - H
ABI17	1800 kg	32,65 kg	700-2000 mm	400x300x650 mm
ABI18	3000 kg	53,15 kg	900-2400 mm	540x340x1300 mm
ABI19	5000 kg	75,55 kg	1000-3200 mm	800x400x1640 mm
ABI21	10000 kg	150,55 kg	1350-3600 mm	900x500x1830 mm

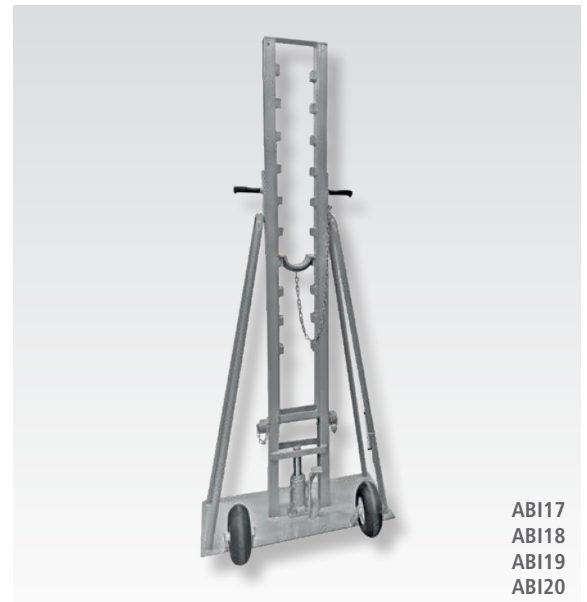

ABI17  
ABI18  
ABI19  
ABI20

- GB** Special accessories and spare parts
- D** Sonder-Zubehör und Ersatzteile
- F** Accessoires spéciaux et pièces de rechange
- E** Accesorios especiales y piezas de repuestos
- I** Accessori speciali e pezzi di ricambio

## AB6025 / AB7525 / AB9025

- GB** Galvanized Steel Drum axis.
- D** Trommelachse aus Verzinkte Stahl.
- F** Axe du tambour en acier.
- E** Eje tubular de acero zincado.
- I** Tubolare in acciaio zincato.



AB9025 - Ø90 mm -1800 mm  
weight 22 kg - 10000 kg load capacity  
suitable for ABI21

AB7525 - Ø75 mm -1500 mm  
weight 17 kg - 5000 kg load capacity  
suitable for ABI16/ABI19

AB6025 - Ø60 mm -1500 mm  
weight 14 kg - 1800 kg load capacity  
suitable for ABI17



Example

## AB6026 / AB7526 / AB9026

- GB** Galvanised steel collar.
- D** Verzinkte Stahlrohrwelle.
- F** Collier de blocage.
- E** Collar de fijación.
- I** Collare di fissaggio.



AB6026 - Ø60 mm -1,90 kg  
AB7526 - Ø75 mm - 2,50 kg  
AB9026 - Ø90 mm - 3,20 kg

## AB6027 / AB7527 / AB9027

- GB** Steel centering cone for tubular.
- D** Feststellkonus aus Stahl.
- F** Collier de blocage en acier.
- E** Cono de sujeción.
- I** Cono di centraggio per bobina.



AB6027 - Ø60 mm - 3,00 kg  
AB7527 - Ø75 mm - 7,00 kg  
AB9027 - Ø90 mm - 8,50 kg

## AMB14/ AMB17

- GB** Cable drum jack worm screw mechanical lifting hand operating with handle.
- D** Mechanischer Kabeltrommelhebebock mit handkurbel.
- F** Chevalets lève-bobines mécaniques avec manivelle.
- E** Gato mecánico para tambores de cables con manivela.
- I** Cavalletto alzabobine a sollevamento meccanico.

Item	Load capacity/ Pair/Coppia	Weight/ Piece	Drum diameter	Dimensions L - W - H
<b>ABM14</b>	4000 kg	30,60 kg	1200-1750 mm	630x440x880 mm
<b>ABM17</b>	7000 kg	38 kg	1500-2700 mm	800x550x910 mm



- GB** Special accessories and spare parts
- D** Sonder-Zubehör und Ersatzteile
- F** Accessoires spéciaux et pièces de rechange
- E** Accesorios especiales y piezas de repuestos
- I** Accessori speciali e pezzi di ricambio

## AB6025

- GB** Tubular unwinding shaft in steel galvanized.
- D** Verzinkte Stahlrohrwelle Ø 60 mm.
- F** Arbre en acier Ø 60 mm.
- E** Eje de acero zincado Ø 60 mm.
- I** Albero tubolare in acciaio zincato Ø 60 mm.



## AB6026

- GB** Galvanized steel collar.
- D** Verzinkte Stahlrohrwelle.
- F** Collier de blocage.
- E** Collar de fijación.
- I** Collare di fissaggio.



## AB6027

- GB** Steel centering cone for tubular.
- D** Feststellkonus aus Stahl.
- F** Collier de blocage en acier.
- E** Cono de sujecion.
- I** Cono di centraggio per bobina.

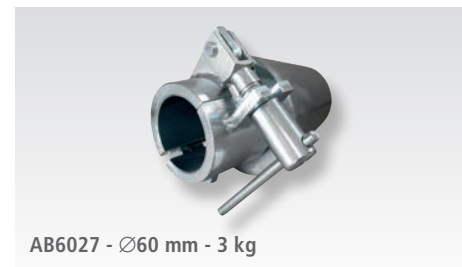

## AB7525

- GB** Galvanized Steel Drum axis.
- D** Trommelachse aus Verzinkte Stahl.
- F** Axe du tambour en acier.
- E** Eje tubular de acero zincado.
- I** Tubolare in acciaio zincato.

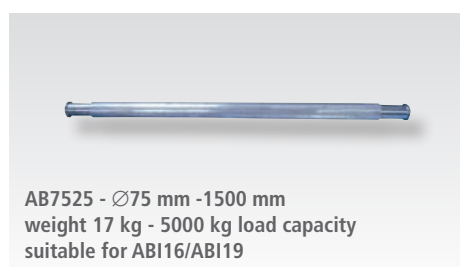

## AB7526

- GB** Galvanized steel collar.
- D** Verzinkte Stahlrohrwelle.
- F** Collier de blocage.
- E** Collar de fijación.
- I** Collare di fissaggio.



## AB7527

- GB** Steel centering cone for tubular.
- D** Feststellkonus aus Stahl.
- F** Collier de blocage en acier.
- E** Cono de sujecion.
- I** Cono di centraggio per bobina.



## PSB10 /PSB15

- GB** Set of unreeling devices with space bar. In strong steel structure galvanized plated finish, with unreeling rollers in aluminium.
- D** Kabeltrommeln-Abroller mit Distanzstab Stahlkonstruktion verzinkt mit Laufrollen in Aluminium.
- F** Système de déroulement pour bobines en acier galvanisé avec des rouleaux en aluminium.
- E** Sistema de rodadura para bobinas en acero galvanizado con rodillos en aluminio.
- I** Pattini di srotolamento con barra distanziatrice. In acciaio zincato e con rulli in alluminio

Item	Reels	Load capacity	Weight	Dimensions L - W - H
<b>PSB10</b>	Ø 400÷1200 mm	1000 kg	13,5 kg	950x110x145 mm
<b>PSB15</b>	Ø 400÷1800 mm	1000 kg	16,5 kg	1050x110x148 mm



EXAMPLE

## PSB20

- GB** Universal steel unwinding system.
- D** Kabeltrommel-Abroller.
- F** Système de déroulement pour bobines.
- E** Sistema de rodadura para bobinas.
- I** Svolgibobina.

Reels	Load capacity	Weight
Ø 200÷700 mm	250 kg	11 kg



PSB20

## GSB28 / GSB29 / GSB30

- GB Hook for lifting drums.
- D Schnell Greifhaken für Kabelstrommeln.
- F Crochet de levage pour les bobines.
- E Gancho para elevación de bobinas.
- I Gancio di sollevamento bobine.

Item	Drum hole diameter	Load capacity	Weight
GSB28	Ø 55 - 110 mm	1000 kg	6,4 kg
GSB29	Ø 60 - 140 mm	2000 kg	8,5 kg
GSB30	Ø 90 - 170 mm	5000 kg	18,0 kg

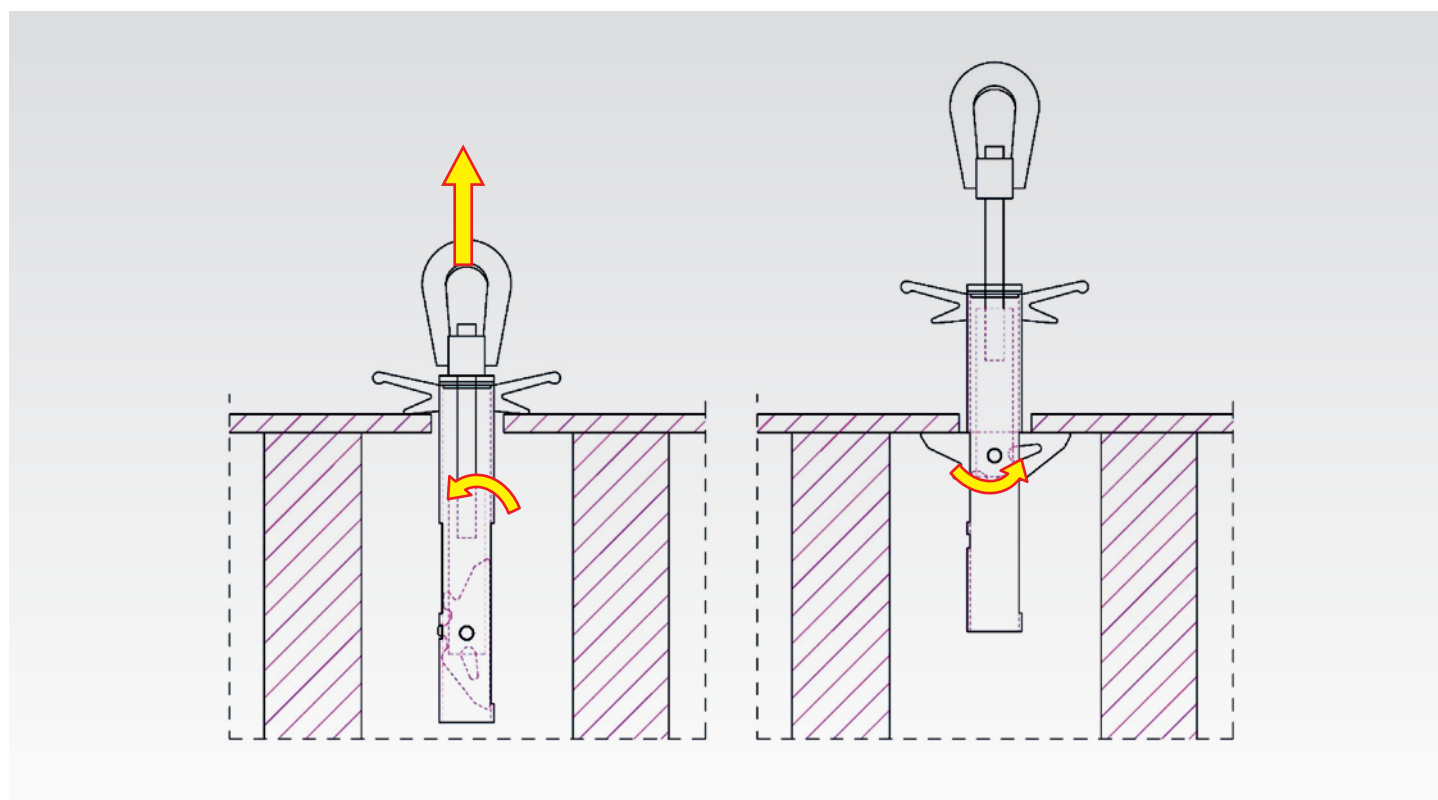

**⚠ This is a device only for professional use. Please read the safety instructions before using the device.**

**Il manuale istruzioni, uso e manutenzione è parte integrante del dispositivo di sollevamento ad uso esclusivo professionale e qualificato.  
L'uso previsto del dispositivo di sollevamento è il solo sollevamento assiale delle bobine.**

## ASB3 / ASB5

- GB** Cable drum **lifting and unroll** beam, with steel wire sling link, markings comply to ECC Directives.
- D** Hebetrasverse mit Zweipunktaufhängung, zum **Heben und Abspulen** von Kabeltrommeln, in Übereinstimmung der Norm für Lastaufnahmemittel
- F** Poutre de **levage et de dérouler** des bobines avec fixation supérieure sur élingue, conformes aux réglementations en vigueur en matière de levage.
- E** Balancin de **elevación y desbobinar** de bobinas con unión superior de tirante, conforme con las normativas vigentes de elevación.
- I** Bilancino di **sollevamento e svolgimento** bobine con attacco superiore a tirante, conforme alle normative vigenti al sollevamento.

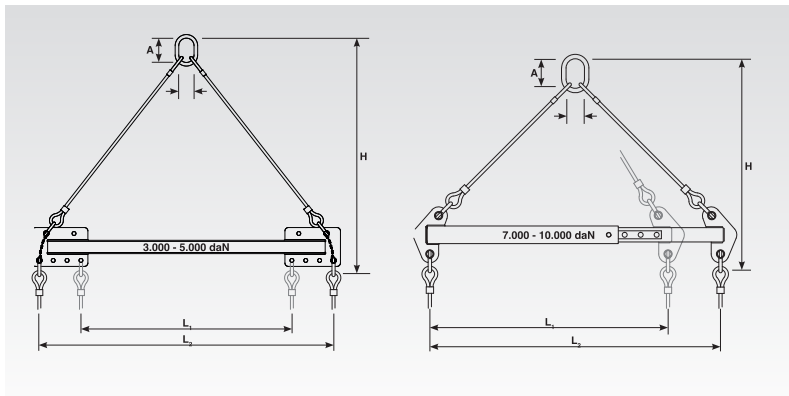

Item	Load capacity	L <sub>1</sub> - L <sub>2</sub>	H	A x B	Weight
ASB3	3000 kg	1500 -2000 mm	1400 mm	175 x 110 mm	90,0 kg
ASB5	5000 kg	1500 -2000 mm	1400 mm	175 x 110 mm	104,0 kg

- GB** Galvanized steel cable roller.
- D** Verzinkte Kabelverlegerolle.
- F** Roule au pose-cable.
- E** Rodillo de guía de cable.
- I** Rullo guidacavo.

Item	Max cable	Weight	Dimensions L - W - H
<b>RG40</b>	∅ 60 mm	3,1 kg	297x140x253 mm
<b>RG50</b>	∅ 90 mm	2,9 kg	295x180x215 mm
<b>RG60</b>	∅ 135 mm	3,6 kg	300x240x250 mm
<b>RG90</b>	∅ 180 mm	4,7 kg	300x275x255 mm
<b>RG100</b>	∅ 260 mm	6,7 kg	350x300x260 mm



Item	Max cable	Weight	Dimensions L - W - H
<b>RG109</b>	∅ 380 mm	7,0 kg	395x500x310 mm
<b>RG110</b>	∅ 200 mm	13,5 kg	510x1000x480 mm
<b>RG111</b>	∅ 300 mm	21,5 kg	495x1000x495 mm

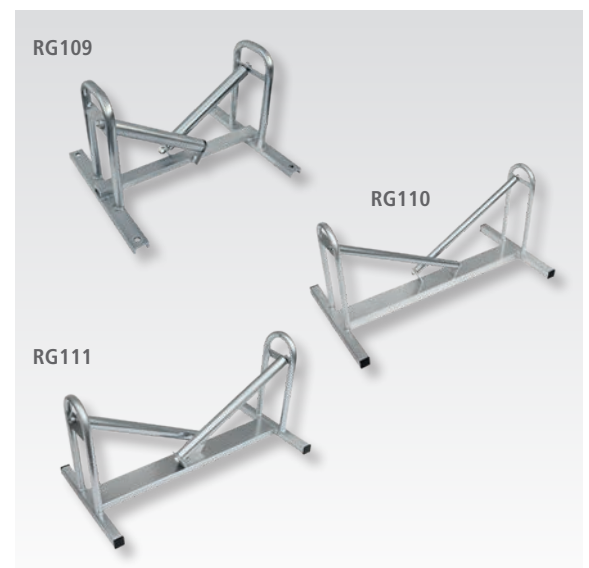

Item	Max cable	Weight	Dimensions L - W - H
<b>RG63</b>	∅ 160 mm	9,0 kg	490x240x400 mm
<b>RG66</b>	∅ 135 mm	27,00 kg	760x250x760 mm



Item	Max cable	Weight	Dimensions L - W - H
<b>RG70</b>	∅ 80 mm	5,9 kg	300x245x150 mm
<b>RG72</b>	∅ 100 mm	6,60 kg	300x245x150 mm

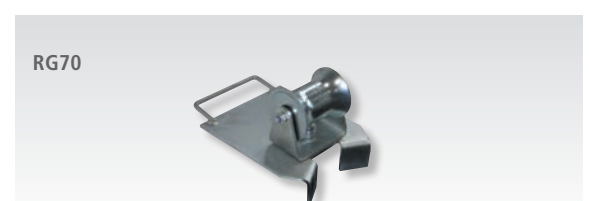

## MEC3 / MEC4 / MEC5 / MEC6

**GB** Cable laying multi-rollers chain device for protection on pass-over cable installations.

**D** Kable und Seilführungskette zum Schutz bei Überquerungen von Leitungen.

**F** Chaîne a rouleaux articulé pour la protection de câble.

**E** Cadena transportadora de rodillos articulados para la protección de cable.

**I** Rulliera a catena snodata per la protezione del sovrappasso di cavi.

Item	Max cable	Weight	Dimensions L - W - H
MEC3	Ø 130 mm	5,1 kg	420x183x110 mm
MEC4	Ø 130 mm	6,8 kg	550x183x110 mm
MEC5	Ø 130 mm	8,5 kg	680x183x110 mm
MEC6	Ø 130 mm	10,2 kg	810x183x110 mm



## RG18 / RG19 / RG20

**GB** Cable protecting socket with quad-rollers guiding frame, mounted on ball bearings.

**D** Verzinktes Kabeleinführgerät zum Schutz von Zugseil/Kabel, mit 4 rollen und Spannvorrichtung zur Befestigung im Rohr.

**F** Dispositif de déviation avec 4 rouleaux monté sur des paliers balle blindé.

**E** Conduit de protección de cables, con 4 rodillos montado sobre cojinetes de esferas apantallados.

**I** 4 rulli guidacavo disposti a cornice.

Item	Leight	Duct	Weight
RG18	360 mm	Ø 51 - 61 mm	3,2 kg
RG19	360 mm	Ø 76 - 86 mm	4,1 kg
RG20	360 mm	Ø 89 - 99 mm	4,8 kg



## AT03 / AT06 / AT08

**GB** Telescopic shaft.

**D** Verstellbare Spannachse.

**F** Barre télescopique.

**E** Eje ajustable.

**I** Asta telescopica.

Item	Range	Weight	Dimensions L - W - H
AT03	324 - 500 mm	9,5 kg	324x205x205 mm
AT06	500 - 720 mm	12,5 kg	503x205x205 mm
AT08	800 - 1300 mm	15,3 kg	800x205x205 mm



## AC1

- GB Plate lifting hook.
- D Drehschlüsselheber.
- F Crochet leve plaques.
- E Gancho de elevación de placa.
- I Gancio di sollevamento chiusini/tombini.



## AC2

- GB Magnetic plate lifter.
- D Magnetischer plattenheber.
- F Lève plaques magnétique.
- E Elevador de placa magnética.
- I Sollevatore chiusini a piastra magnetica.



## BE1

- GB Manhole barrier, **foldable**.
- D Schachtabsperrung, **faltbar**.
- F Barrière extensible, **pliable**.
- E Barrera de alcantarilla, **plegable**.
- I Barriera stradale per chiusini/tombini, **piegabile**.

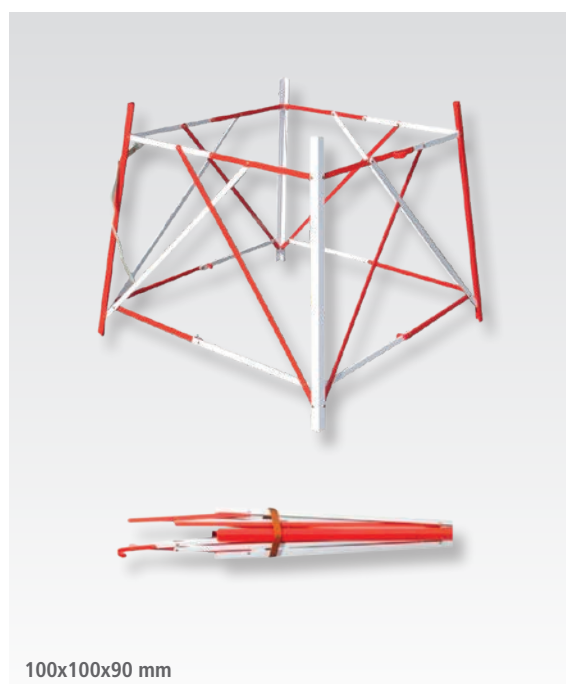

# Rapido Lubricants

## Rapido 1

- GB** Suggested to remove the old cables and also to insert the new cables. Biodegradable and not toxic.
- D** Geeignet um die alten Kabel herauszuziehen und auch die neuen Kabel einzuziehen. Biologisch abbaubar und nicht toxisch.
- F** Recommandé pour enlever les vieux câbles et d'insérer les nouveaux. Biodégradable et atoxique.
- E** Recomienda retirar los cables de edad y también para insertar el nuevo.
- I** Suggestito per rimuovere i vecchi cavi e anche per infilare i nuovi. Biodegradabile e non tossico.

Item	Description	
RAPIDO.1	1 lt	15
RAPIDO.5	5 lt	1



Rapido 1

Rapido 5

## Rapido Gel

- GB** Lubricant Gel. Reduce 80% the friction effect during installation of electrical, telephone, fiber optic and coaxial cables.
- D** Gleitmittel Gel. 80% Reibungsreduzierung beim Einzug von Elektro, Telefon, Glasfaser und Koaxialkabel.
- F** Lubrifiant Gel. 80% réduit le frottement dans l'installation de câbles électriques, téléphoniques, fibres optiques et coaxiaux.
- E** Lubrificante Gel. 80% reduce la fricción durante la instalacion de cables eléctricos, telefónicos, de fibra óptica y coaxial.
- I** Gel lubrificante. Riduce dell'80% l'attrito durante la posa dei cavi elettrici, telefonici, fibra ottica e coassiali.

Item	Description	
RAPIDO GEL.025	250 ml	50
RAPIDO GEL.1	1 lt	15
RAPIDO GEL.5	5 lt	1



Rapido Gel.025

Rapido Gel.1

Rapido Gel.5

**R5 GB** Dispenser **D** Spender **F** Distributeur **E** Dispensador **I** Dosatore

**R1 GB** Vaporizer **D** Zerstäuber **F** Vaporisateur **E** Pulverizador **I** Spruzzatore



R5



R1

## Profi Spray

- GB** Spray foam. Reduce 70% the friction effect during installation of electrical, telephone, fiber optic and coaxial cables.
- D** Gleitmittel Schaumspritze. 70% Reibungsreduzierend beim Einzug von Elektro, Telefon, Glasfaser und Koaxialkabel.
- F** Mousse Spray. 70% réduit le frottement dans l'installation de câbles électriques, téléphoniques, fibres optiques et coaxiaux.
- E** Espuma Spray. 70% reduce la fricción durante la instalacion de cables eléctricos, telefónicos, de fibra óptica y coaxial.
- I** Schiuma Spray. Riduce dell'70% l'attrito durante la posa dei cavi elettrici, telefonici, fibra ottica e coassiali.

Item	Description	
PROFI SPRAY.040	400 ml	12



Profi Spray.040

## Easyisogel

**GB** This is a high viscosity gel which, by effect of gravity, is able to take all spaces, hollows, gaps inside the container where it is placed. It is a ready for use product, non stick, non oily, and is transparent and odourless. Thanks to its special formula, Easyisogel is inert to temperature changes, to ageing and may be reused several times. It is self-agglomerating and has remarkable isolating power.

- Self-levelling - takes all spaces inside the container
- Self-agglomerating - does not need being amalgamated
- Ready for use - does not need mixing
- Reusable - does not solidify, does not decay
- Removable - at any time, even after years
- Non-toxic - it is not hazardous for humans, animals or the environment
- Dielectric - excellent isolating power: 15 kv
- Transparent - it lets you check the condition of connections at any time
- Non stick - it does not remain and does not soil surfaces

**IT** Gel isolante ad alta viscosità, si auto-installa nelle cassette di derivazione riempiendo ogni spazio libero annegando i cavi, le connessioni e le giunte.

- Autolivellazione
- Pronto all'uso (non necessita miscele)
- Rimovibile e riutilizzabile
- Non tossico, non sporca
- Trasparente ispezionabile
- Dielettrico



EASYISOGEL.05



EASYISOGEL.025



EASYISOGEL.028

Item	Description	
EASYISOGEL.05	500 gr can	4
EASYISOGEL.025	250 gr tube	12
EASYISOGEL.028	280 gr syringe	12
EASYISOGEL.5K	500 kg drum	1

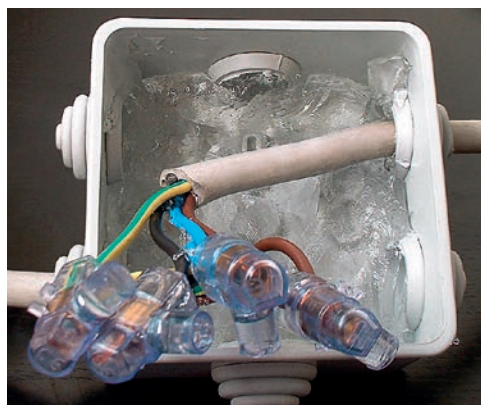

Lay one portion of Easyisogel on the bottom of the box. Perform wiring.



Fill the box well with Easyisogel, without leaving any empty spaces.



Close the box cover.

## Idro rapido

**GB** Water based acrylic paint, the best way to trace, mark or border any wall or surface, report the presence of pipes.  
Environmentally-friendly product.

**IT** Tracciante di pittura acrilica a base d'acqua.  
La migliore soluzione per segnalare la presenza di tubazioni murate o per indicare le tracce da effettuare nei muri per la posa del tubo corrugato e delle cassette di derivazione.  
Prodotto non tossico per l'uomo e l'ambiente.



IDRORAPIDO

Item	Description	
IDRORAPIDO.MIX	Assorted color 400 ml Black / blue / red	12
IDRORAPIDO.N	Black spray can 400 ml	12
IDRORAPIDO.B	Blue spray can 400 ml	12
IDRORAPIDO.R	Red spray can 400 ml	12

- GB** Solid empty display with 8 hooks.  
Set up as you like.
- D** Solide leerer Verkaufsständer mit 8 Haken. Montiere wie Du willst.
- F** Solid display avec 8 crochets.  
Composer comme vous voulez.
- E** Solido espositor vacío con 8 ganchos.  
Sortijelo come quieres.
- I** Solido espositore vuoto con 8 ganci.  
Allestisci come vuoi.

Here Your brand  
Hier Ihre Marke  
Ici votre marque  
Aquí su marca  
Qui il vostro logo



Expo.1

- GB** Solid empty display with 6 hooks and 1 brackets.  
Set up as you like.
- D** Solide leerer Verkaufsständer mit 6 Haken und 1 Konsole. Montiere wie Du willst.
- F** Solid display avec 6 crochets et 1 plateau.  
Composer comme vous voulez.
- E** Solido espositor vacío con 6 ganchos y 1 repisa. Sortijelo come quieres.
- I** Solido espositore vuoto con 6 ganci e 1 mensola.  
Allestisci come vuoi.

Here Your brand  
Hier Ihre Marke  
Ici votre marque  
Aquí su marca  
Qui il vostro logo



Expo.2

## Copyright © by ARLINE S.r.l.

- GB** All items photographed in the Catalogue are protected by intellectual right. Under no circumstances will any logo, trade mark and photograph be imprinted to any catalog and media or photocopy to third party without the permission of the legal owner. Any infringement of intellectual rights in structure patent, design and trade mark in the catalogue is a serious offence and all violator will be prosecuted.
- D** Alle Texte, Bilder und Grafiken in diesem Katalog unterliegen urheberrechtlichem Schutz. Wer Werke oder Werkteile dieser Seitennutzen möchte, soll sich bitte an den Urheber wenden.
- F** Tous droits réservés. La reproduction, meme partielle, est autorisée seulement du propriétaire des droits.
- E** Reservados todos los derechos. La reproducción incluso parcial está permitida solo después de la autorización del propietario de los derechos.
- I** È vietata la riproduzione parziale o totale del catalogo senza il preventivo consenso scritto del proprietario.

<b>ORDINI</b>	Le commissioni assunte dalle nostre Agenzie sono soggette all'approvazione della nostra direzione commerciale.
<b>MODIFICHE</b>	Ci riserviamo la facoltà di apportare, in qualsiasi momento e senza alcun preavviso, delle modifiche migliorative alle caratteristiche tecniche, estetiche, normative dei nostri prodotti.
<b>QUANTITÀ MINIME</b>	Quantità inferiori alle confezioni minime verranno automaticamente arrotondate alle stesse.
<b>MINIMO D'ORDINE</b>	Non verranno evasi ordini di importo inferiore a € 200,00 + I.V.A.
<b>IMBALLO</b>	Compreso.
<b>TRASPORTO</b>	PORTO FRANCO per ordini oltre € 400,00 + I.V.A.; per ordini di importo inferiore, PORTO FRANCO con addebito di € 25,00 + I.V.A.; o PORTO ASSEGNATO a mezzo del corriere indicato dal cliente. In caso di indisponibilità parziale di materiale, il residuo d'ordine verrà evaso in porto franco se il relativo importo è superiore al minimo evadibile.
<b>TERMINI DI CONSEGNA</b>	<p>i termini di consegna si intendono indicativi e non impegnativi. Ci riserviamo di cancellare, del tutto o in parte, articoli che, per qualsiasi ragione, non fossero disponibili, anche dopo l'accettazione della commissione. In nessun caso di ritardo delle spedizioni e delle consegne, l'acquirente può rifiutare la merce o chiedere indennizzi di qualsiasi tipo.</p> <p>La merce si intende venduta sempre franco nostro magazzino di Cinisello Balsamo e viaggia a rischio e pericolo dell'acquirente, anche se spedita in porto franco. Per eventuali contestazioni dovute a rotture o mancanze di colli, ritardi, avarie....., il cliente deve avvalersi esclusivamente nei confronti del corriere, all'atto della consegna, dandocene comunque comunicazione scritta per poter intervenire a suo favore.</p>
<b>RECLAMI</b>	Qualsiasi reclamo deve, sotto pena di decadenza, essere proposto a mezzo lettera raccomandata da inviare alla ARLINE SRL entro il termine di 8 giorni dal ricevimento della merce.
<b>RESI</b>	Non si accetta merce di ritorno senza nostra autorizzazione scritta. Eventuali resi si intendono franco nostro magazzino. Per le modalità di autorizzazione al reso si prega di prendere contatto con l'agenzia di zona. Verrà respinto al mittente qualsiasi reso non espressamente da noi autorizzato.
<b>PAGAMENTI</b>	Nel caso di ritardo nei pagamenti concordati non verranno effettuate ulteriori forniture.
<b>RISERVA DI PROPRIETÀ</b>	La fornitura si intende fatta e accettata con il patto di riservato dominio fino al totale assolvimento degli obblighi di pagamento con noi assunti.
<b>PREZZI</b>	I nostri prezzi di vendita si intendono I.V.A. esclusa e non sono impegnativi. Potranno essere aumentati con particolare riferimento alla fluttuazione del costo delle materie prime di qualità e la difficoltà di reperimento delle stesse. L'acquirente riceverà preavviso scritto della variazione dei prezzi prima della nostra conferma d'ordine.

FORO COMPETENTE: ad ogni effetto si intende il foro di Milano.

**TUTTE LE CONDIZIONI DESCRITTE SONO ACCETTATE DAL CLIENTE,  
ALL'ATTO DEL CONFERIMENTO DELL'ORDINE,  
ANCHE SE NON ESPLICITAMENTE SOTTOSCRITTE.**



# ARLINE

---

ARLINE S.r.l.

Via Pellizza da Volpedo, 57/59

20092 Cinisello Balsamo (MI) - ITALY

Tel. +39.02.61293094 - Fax +39.02.61461765

info@arline.it

---

[www.arline.it](http://www.arline.it)